

The British Sundial Society

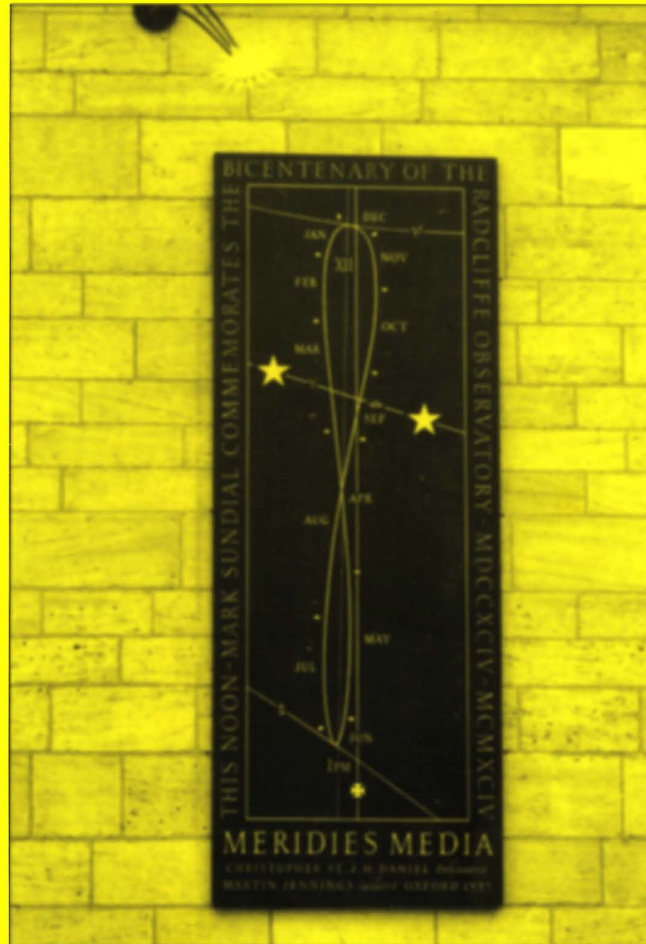

BULLETIN

VOLUME 12 (ii)

JUNE 2000



Front Cover: Meridian Dial, Green College, Oxford (designed and photographed by C. Daniel)

Back Cover: Armillary Sphere, formerly at Chippenham, Cambridgeshire (photo by M. S.)

VOLUME 12 (ii) - JUNE 2000

CONTENTS

- 53. EDITORIAL
- 55. A SUNDIAL FOR CHRIST CHURCH, OXFORD, BASED ON A DIAL BY NICHOLAUS KRATZER - *David M. Brown*
- 59. THE MAKING OF THE CHRIST CHURCH SUNDIAL - *David M. Brown*
- 64. GRAECO-ROMAN SUNDIALS, PART II: CONICAL AND OTHER FORMS - *Allan A. Mills*
- 70. THE NOON DAY STONE AT ST. MARTIN'S CHURCH, HORSLEY, GLOUCESTERSHIRE - *Tony Wood*
- 72. PRIVATE SUNDIALS - *Margaret Stanier*
- 73. SOME MASS DIALS IN NORMANDY - *John Lester*
- 76. THE GATTY FAMILY - PART 1 - *Mike Cowham*
- 81. THE BSS AWARDS SCHEME
- 84. JAMES GREGORY'S MERIDIAN LINE AT ST ANDREWS UNIVERSITY, 1673 - *John Amson*
- 86. 'CAMBRIDGE SUNDIALS OLD AND NEW': LECTURE REPORT
- 87. READERS' LETTERS
- 88. BOOK REVIEW: 'THE SUN IN THE CHURCH'
- 90. PHOTOGRAPHING THE TOTAL ECLIPSE OF THE SUN IN BULGARIA, 11TH AUGUST 1999 - *Robert B. Sylvester*
- 91. NOTES FROM THE EDITOR
- 91. THE SEARCH FOR PRE-SAXON SUNDIALS - *John Wall*
- 96. DIAL DEALINGS - *Mike Cowham*
- 99. PHOTOGRAPHING MASS DIALS - *Tony Wood*
- 101. AN EDUCATIONAL HELIOCHRONOMETER - *Andrée Chotkiewicz*
- 103. A PORTABLE ANALEMMATIC DIAL - *John Singleton*

BULLETIN

OF THE BRITISH SUNDIAL SOCIETY

ISSN 0958-4315

VOLUME 12 (ii) - JUNE 2000

EDITORIAL

A notable theme in this issue of the Bulletin is the interest in Meridian Lines and Noon Marks, a topic brought at once to mind by the cover-picture of Christopher Daniel's splendid Meridian Dial at Green College, Oxford. James Gregory's 17th century Meridian Line at St Andrews, the earliest meridian line of known date in Britain, is the subject of an interesting article by John Amson. The extraordinary Noon-Mark-Stone in a west country churchyard is described by Tony Wood and photographed as the church tower shadow rushes across it. Then there is the well-written review by C.M.Lowne of Heilbron's book 'The Sun in the Church', which describes the setting-up of the great meridian lines in cathedrals on the Continent of Europe, from the sixteenth century onwards. Most of these lines, some of which are very beautiful, were set up after the Gregorian reform of the calendar of 1582. It will come as a surprise to many that for over a hundred years - early

sixteenth to mid-seventeenth century - the (Roman Catholic) Church was the chief patron and supporter of the study of astronomy in Europe. It was only when telescopes became more widely made and used that the study of astronomy shifted to scientific institutions and universities, some under royal patronage.

We understand that Andrée Gotteland of the French Sundial Society (Commission des Cadrans Solaires) is preparing a book about the Meridian Lines of Europe. In writing to enquire about such lines in Britain, she asked why there were so few in Britain as compared with other European countries; at that time she had only 4 British meridians on her list. Members of our Society soon brought up this number to at least a dozen. We are hoping to acquire a copy of her book in due course for the Society's library.

A SUNDIAL FOR CHRIST CHURCH, OXFORD, BASED ON A DIAL BY NICHOLAUS KRATZER

DAVID M. BROWN

BACKGROUND

This dial is based on one designed and built by Nicolaus Kratzer around 1520. His dial stood in Corpus Christi College garden until the end of the seventeenth century but subsequently disappeared. Fortunately it was sketched by Robert Hegge in 1624 - 5¹. There are other illustrations taken from the same manuscript² in *The Book of Sun-Dials* by Eden & Lloyd (after Mrs A. Gatty)³.

This dial was adjudged the winner of the competition set up in 1996 by Christ Church with the help of the British Sundial Society.

The design criteria for the dial were that the dial should be free-standing, durable, and not prone to vandalism; that it should combine elegance with utility and intellectual interest, and also be to a scale appropriate to the garden. A further restriction referred to the overall cost of the dial. Inspiration came from Kratzer's work. He is regarded as one of the founding fathers of dialling in Britain. He was also at Corpus Christi under the auspices of Cardinal Wolsey whilst Cardinal College (later Christ Church) was being built so had a link to Christ Church. Furthermore, only two of his dials still exist⁴, and it seemed to me that it would be a fine thing to create something which had a flavour of Kratzer in it.

The dial described herein stands in Pocock Garden at Christ Church barely 50 m from the point at which the original stood in Corpus. It can be seen from Corpus as well as from the Christ Church Meadows building and others. As many as possible of the features of Kratzer's dial have been incorporated and modifications have overcome some the original's shortcomings. The size is close to that of the original.

The dial was installed in October 1998 and carries a dedication to Joan Page who was a long-standing College Secretary and a benefactor, and through whose generosity the Pocock garden was recently renovated.

DESCRIPTON OF THE DIAL

General Description:

The dial has the basic form of a rectangular prism from which five plane faces have been recessed, one concave surface taken and one hemispherical surface added.

In all there are 11 dials and 24 gnomons

The dials are,

- | | |
|----------------|--|
| on the N face: | Equatorial for summer months, using two edges of the dial as morning and afternoon gnomons. |
| W face: | Direct, with rectangular gnomon carrying a nodus. |
| S face: | Berosus, with triangular gnomon. Direct, with triangular gnomon. Equatorial, for winter months, with pin gnomon. Polar, with rectangular gnomon carrying a nodus notch. |
| E face: | Direct, with plain gnomon having ogee sides. |
| Top face: | Horizontal, morning hours, triangular gnomon. Horizontal, afternoon hours, triangular gnomon. Hemispherical, with a pin gnomon on each of thirteen meridians at 15° spacings. Equatorial with a pin at the simulated N pole of the hemisphere. |

Size:

The upper horizontal surface is 1150 mm above the ground, and the hemisphere rises 125 mm above that. The main body of the dial is rectangular in plan, 300 x 500 mm. The main dial section rises 725 mm above the plinth. The plinth in turn is 425 mm high and 580 x 375 mm at its greatest dimensions. The whole structure stands on a paviours with a firm foundation prepared by the college ground staff.

Materials:

- | | |
|------------------|--|
| Dial and plinth: | Portland stone, fashioned by Drings of Bath in three sections - plinth, dial body and hemispherical top with central holes drilled in each of the two large sections so that Lewis pins could be inserted for lifting. In its fixed position the sections are bedded on portland stone dust lime mortar. |
| Gnomons: | Phosphor Bronze 3.3 mm sheet and 3 mm rod set in epoxy mixed with stone dust. |

Paints: Best signwriter's enamels,
 Grey for all lettering and lines
 unless described otherwise
 Red for hour lines
 Blue for date lines
 Green for zodiac lines.
 Gold leaf is set on oil size.

Incisions & lettering:

All v-cut by hand unless otherwise stated. Lettering style Trajan Roman. Arabic numerals. Noon marks are crosses.

DESCRIPTION OF THE FACES

North face (working from the top downwards)



North Face

Top Surface, reclining at 38.25°

The Equation of Time graph, corrected for longitude, with instructions for using it.

Main Surface

The Cardinal's hat and tassels, taken from the Christ Church coat of arms.

Inclining Surface (at 51.75°)

Accreditation DAVID BROWN DELINEAVIT ET FECIT 1998. A quarter sunburst in each of the lower corners pairs up with similar quarter sunbursts on the reclining face below, to give rising and setting suns on the east and west sides of the dial. The gilding on these sunbursts catches the

light to illuminate what would otherwise be a dark part of the dial.

Lower Reclining Surface (at 38.25°)

An equatorial dial for the summer months. There are two gnomons for this dial, formed by the edges of the face above it, so there are two sets of hour lines each radiating out from those edges, one for the morning, one for the afternoon. The consequence of this is that the numerals seem rather jumbled. This is intentional because it was at Christ Church that Lewis Carroll wrote Alice in Wonderland, and the "curiouser and curiouser" nature of this face helps to fulfil the design criterion of the dial that it should be 'intellectually stimulating'. As a further sideways look at the world through the looking glass, the hour lines have been left standing proud whilst the background has been chiselled away. On all the other faces, the reverse is the norm.

The Plinth below carries the dedication:

IN MEMORIAM JOAN PAGE

West Face

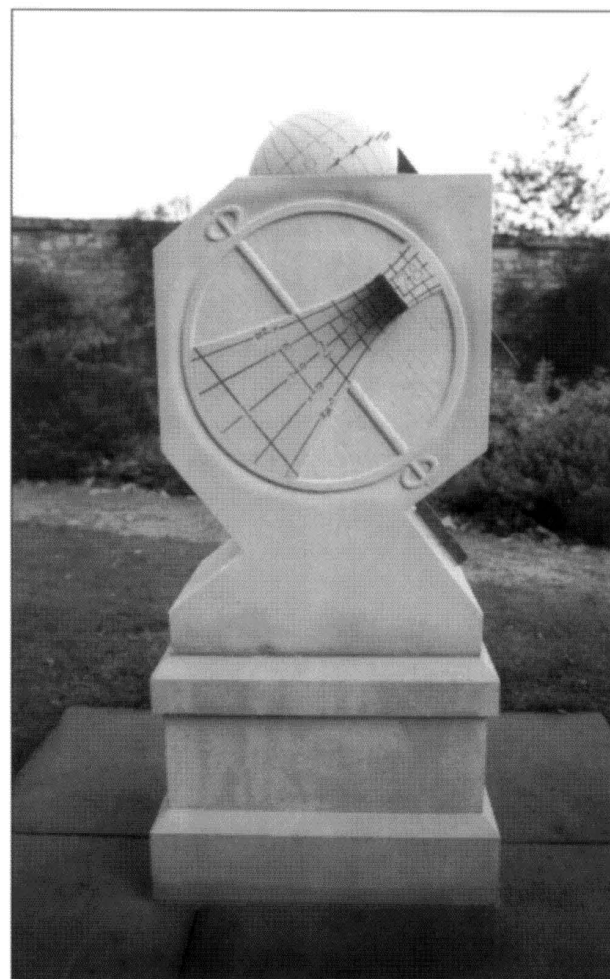

West Face

Hegge's drawing of Kratzer's dial shows a dial on the east face which has the suggestion of a universal equinoctial ring dial, crossed with an astrolabe. It looks very uncomfortable. I am not sure whether this is because of inaccuracies in Hegge's drawing or whether the 'axis' really was wrongly placed over the dial graduations. I decided to put my version of it on the west face, and get the alignment and positioning of the axis correct and looking more at ease. The dial is otherwise a conventional direct west dial with zodiac date lines. The nodus is formed by the almost-meeting points of a circular hole, tangential to the style. This feature is reminiscent of the tails of the dolphins in the well-known dolphin dial at Greenwich. Its real source of inspiration was some beautiful pop-up dials I had seen in ancient books in the library at Downside Abbey.

South Face

Top

A Berosus type dial, showing canonical hours bounded by solstice lines. The equinoctial line runs between the two cusps. In Kratzer's dial there is a hemispherium cut into the upper horizontal surface. This must have been a great collector of water and leaves. I took a more straightforward option so that drainage would not be a problem.

When viewed from a position a short distance away from this south face, the Berosus dial and the hemisphere of the dial mounted on the top surface give the appearance of a complete sphere. This was intentional because Kratzer's dial had a sphere but it was mounted on metal (iron?!) arches above the main body of the dial - an awkward structure, making his uppermost spherical dial difficult to read and obstructing inspection of the recessed hemispherium.

Upper Vertical Surface

A direct south dial with a gilt sunburst and noon Latin cross. Gilt dots show the half-hours. The latitude and longitude are inscribed but unpainted. The year of making 1998 is inscribed and painted in blue.

Inclining Surface (at 51.75°)

An equatorial dial with pin gnomon. This dial is illuminated only in the winter months.

Reclining Surface (at 38.25°)

A polar dial with a plain gnomon carrying a nodus notch. The numerals are in binary code, starting with 00111 for 0700hrs, 01000 for 0800, etc. up to 10001 for 1700hrs. The reasons for this choice of numerals were

- (i) that they do not take up as much space left and right as Arabic numerals (and space was restricted, particularly close to the gnomon)

- (ii) the fact that in this computer age all computers use binary code in their timing and calculating processes.
- (iii) the intellectual challenge for the users of the dial.
- (iv) the use of 24hr clock notation is important in astronomical reckoning.

Zodiac date curves and signs are included.

Lower Vertical Surface

My mason's mark, a stylised 'dmb'.

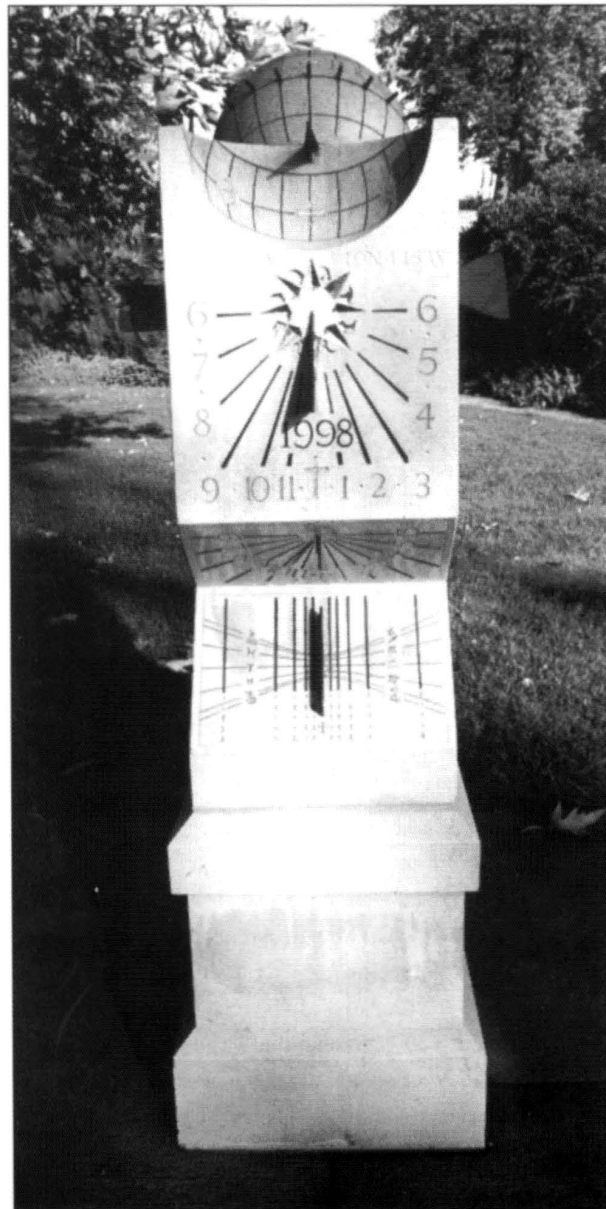

South Face

East Face

This shows a dial similar to that shown on the east face of Kratzer's small gilt brass dial given to Cardinal Wolsey. It is a plain direct east dial. Gilt stars have been left proud of a recessed rough-hewn background.

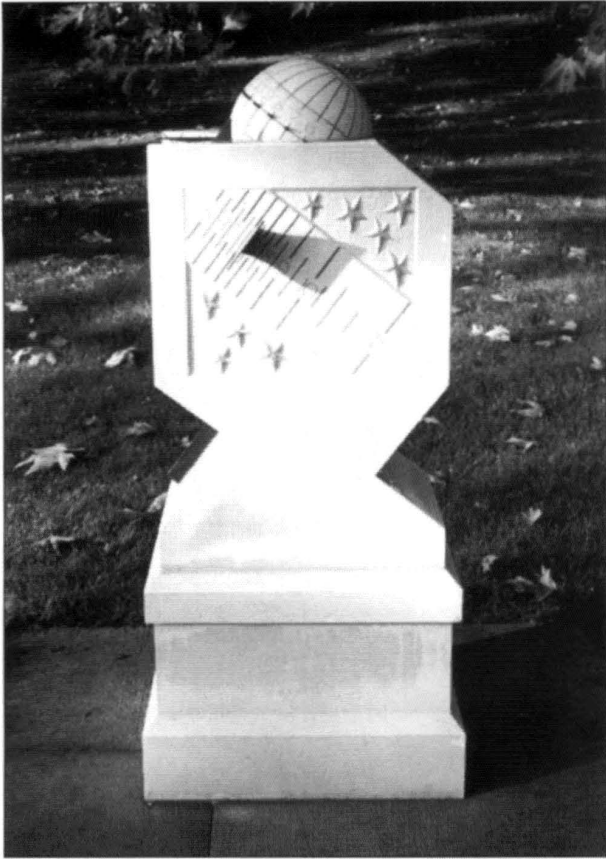

East Face.

Top Surface

The hemispherical surface was chosen as an improvement on Kratzer's leaf-and-water-catching recessed hemispherium whilst still retaining a part-spherical feature to echo the full sphere on the original. The lines are cut to represent meridians, or lines of longitude as central time-zone lines at 15° intervals on the surface of the Earth. A short pin gnomon is inserted at the place where each of these lines cuts the equator. Each one acts as a gnomon. The dial user looks to see which one gives the shortest shadow, which will also be in line with its meridian. The hour on that meridian is the time and can be read from the numerals on the meridian. This particular dial has a good educational point. The shadow of a vertical stick is shortest at noon and is on the meridian at that time. A single stick in one location

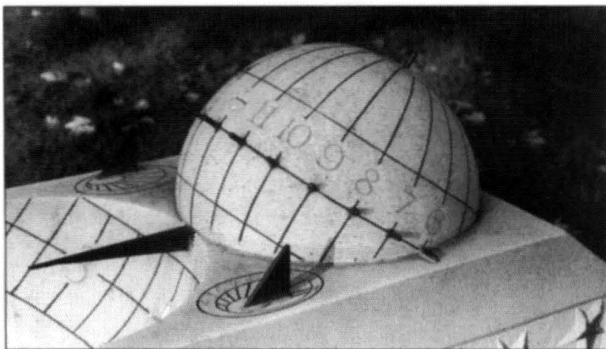

Top Face

has to be observed throughout the day to get a sense of this change in shadow direction and length, whereas the whole of a day's-worth of shadows can be seen at a glance on this dial by comparing the shadows from all of the pin gnomons.

The pole of this hemisphere also has a single pin gnomon and with the meridian lines continued from the previous dial forms an equatorial dial at the pole. The pole will be lit only in the summer months.

Circles of latitude included on this dial are the tropics and the arctic circle. A rough estimate of the date can be made either from the position of the shortest shadow of the equator pins (most accurate close to the equinoxes) or from the shaded portion of the hemisphere near to the arctic circle. (At the winter solstice, the shadow will come to the upper edge of the circle. At the summer solstice, the lower edge will just be lit. At the equinoxes, the shadow area will just pass through the foot of the polar pin.)

The top surface also carries two small horizontal dials, one for the morning hours on the east side, and a matching one on the west side for the afternoon hours.

In Kratzer's dials the gnomons all appear to be triangular with only the pointed tip on many of them acting as the time/date indicator. I felt that this would be a possible hazard to less careful users of the dial, so opted for other style shapes, with rounded corners.

REFERENCES & NOTES

1. Pattenden, P. *Sundials at an Oxford College*, Roman Books 1979
2. MSS CCC 40 in the Corpus Christi Library
3. e.g. in the 1900 edition of Gatty's '*Book of Sun-Dials*', p.90
4. A small gilt brass polyhedral dial which Kratzer made for Cardinal Wolsey (1522-30) in the Museum of the History of Science, Oxford. There is also a remnant of a failed dial by Kratzer from Iron Acton Court in the City of Bristol Museums and Art Gallery.

*Author's address:
21 Radstock Road
Midsomer Norton
Bath, Som. BA3 2AJ*

THE MAKING OF THE CHRIST CHURCH SUNDIAL

DAVID M. BROWN

In this beautifull Alter (on which Art hath sacrific'd such varietie of invention to the deitie of the Sun) are twelve gnomons, the Suns fellow travellers, who like far-distant inhabitants, dwell some under the Equinoctiall; some under the Poles; some in more temperate climates; some upon the Planes in Plano; some in the vallies in Concavo; & some upon ye mountains in Convexo. Here you may see the Equinoctial dial the Mother of ye rest; who hath the Horizons of the parallel Spheer for her dubble Province, which suffer by course an half-years night. There lyeth the Polar Dial, wing'd with the lateral meridian. Here stands the two-fac't verticall Dial, & shakes hands with both Poles. There the Convex dial, elevated in triumph upon 4 iron arches. Here lastly the concave dial which shews the Sun at noon day the hemispheer of Night. In other dials neighboring clocks betray their errours; but in this consort of Dials as informed with one soul of Art, move all with one motion: and write with their Styles ye prayse of the Artificer.

So wrote Robert Hegge in 1624 when describing and drawing a dial at Corpus Christi College, placed there by Nicolaus Kratzer soon after arriving in Oxford in 1521. Kratzer had come to the court of Henry VIII in 1517/1518 as astronomer and 'deviser of the king's horologes'. He later taught astronomy to the children of Sir Thomas More before entering the service of Cardinal Wolsey. It was Wolsey who was at least partly responsible for Kratzer's arrival in Oxford. Kratzer was in Oxford during 1521 - 1524 probably as Cardinal Wolsey's lecturer in elementary scholastic astronomy at Corpus Christi College pending the completion of the adjacent foundation Cardinal's College. Wolsey founded Cardinal's College in 1525, but died disgraced in 1530. The College was re-founded as King Henry VIII's College in 1532 and became Christ Church in 1546. This elaborate dial at Corpus Christi College was one of only four that can definitely be attributed to Kratzer. Of these only two survive. One is a small gilt brass dial given to his patron Wolsey when he was archbishop of York and is now in the Oxford Museum of the History of Science.

The other was found recently as a building block in a wall at Iron Acton Court, near Bristol, made in 1520 but rejected as an incorrectly-made dial. It is now in the City of Bristol Museums and Art gallery. Of the remaining two, one was mounted on a pillar dial at St Mary's Church, Oxford in 1523, and undoubtedly acted as a source of inspiration for the Turnbull (Pelican) dial which now stands in the quad at Corpus Christi.

The last of the four dials, and the inspiration for my new one, disappeared early in the eighteenth century. It stood, however, about 50 metres from the position of the new one that can be seen from the high rampart wall in the Corpus garden which overlooks Pocock's Garden at Christ Church.

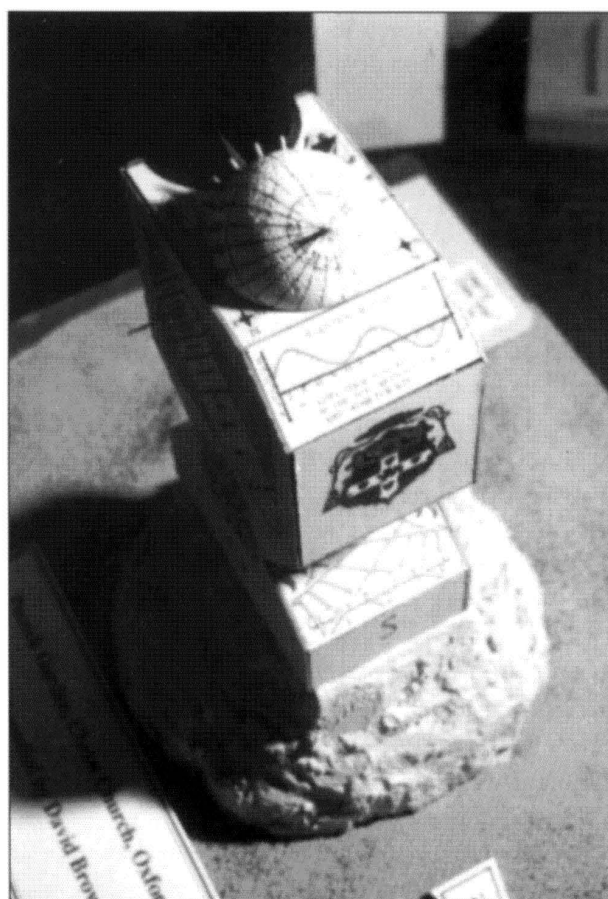

Scale model (1/10) of initial design in card, wood and polystyrene.

I mention all this because it seemed to me that when deciding to enter a design for a sundial competition set up by Christ Church with the help of the British Sundial Society in 1996 it would be very fitting to bring back to Oxford a dial very similar to Kratzer's. Not only would it be placed close to the site of Kratzer's original dial and fulfil the criteria set out by the devisers of the competition but it would add to the general body of sundialling knowledge and styles. At the same time it would add substance to Kratzer's and Hegge's historical documents which carried only drawings and description.

Thus began the process which culminated in the dial now standing in Pocock's Garden at Christ Church, and I hope that in recounting some of my experiences on the way

others will find enjoyment, enlightenment and inspiration for other sundial projects. I have used a diary and note format and have tried to be as concise as memory and space allow.

1996 EARLY AUTUMN

Received details of competition from BSS (David Young) and replied that I would enter.

12 DEC

Went to Christ Church to meet Treasurer (at the time) Richard Benthall and to inspect the Pocock's Garden site. Noted proximity of large Oriental Plane Tree planted in about 1660, garden wall, to east, tall Meadows building to south and Cathedral to west. Limited sunlight in winter. Probably OK in summer. Leaves might be a problem. Bought some College publications at the Cathedral bookshop to help researches.

REST OF DEC. AND INTO NEW YEAR

Read thoroughly *Sundials at an Oxford College* (P.Pattenden), all references to Kratzer in Mrs Gatty / Eden & Lloyd *The Book of Sun-Dials* and *BSS Bulletins*. Noted that Lewis Carroll (C.L.Dodgson) wrote *Alice in Wonderland* from Christ Church and that in *Alice Through the Looking Glass* there is a lengthy reference to 'toves' from Jabberwocky making their nests under sun-dials. Thought it was going too far to include specific references to this in my dial, but would try to include some puzzling features for intellectual challenge.

1997 20 JAN

Completed drawings. Showed dial standing on a rough-hewn rock, intending that this should give the impression of the dial having been fashioned from a complete stone as well as to give a safety margin round the dial so that users would not impale themselves on or damage protruding gnomons. Wrote to a number of stone suppliers for quotations on the cost of supplying and fashioning the dial shape (no incision work to be done). These varied from total rejection of the idea as a single piece of black slate, through approx £500 to £1000 for a limestone block to £16,000 (+ VAT!) for green slate. In the end, decided on a realistic option for purpose of design submission - there was a cost limit.

24 JAN

Discussed structure requirements/strengths of foundation etc. with estates manager at Kingswood School, Bath (where I was teaching at the time). Modified drawings accordingly.

END OF JAN

Made working scale model in card, polystyrene, wood, 1/10 full size, with all details included. (Fig. 1) Added 5 Imperial-size display panels having copies of drawings together with historical references and explanatory texts.

FIRST WEEK OF FEB

Took model and display panels to Christ Church. Received acknowledgement and info. that there had been twelve designs submitted.

END OF MARCH

Received news of having won the competition. Amazed, honoured, frightened. Discussed some details with the Treasurer at Christ Church.

10 MAY

Sent revised plans. Changed rough-hewn rock for formal plinth. Dropped some features - full Christ Church coat of arms simplified to just cardinal's hat. No St.Frideswide. No letters O (for Occidens) on west face, M (Meridies) on south face, O (Oriens) on east face or, rather disappointingly, S (Septentriones) on the N face. This last one would have been quite a puzzler because a letter S would have been on the N face. Ah, well! Sent details and asked for final quotation for Portland Whitbed stone plinth and dial shape from Drings (Bath) Ltd. (now Hanson Bath and Portland Stone).

20 MAY - 3 JUNE

Entries on display at the Christ Church Picture Gallery. (Wow!).

JUNE - JULY

Made full-size working model in wood, MDF, thermalite block covered in plaster (for spherical surfaces) all painted, decorated etc. (Fig. 2). Finished with much suffering and anxiety two days before youngest daughter's wedding, and took to Christ Church for their final approval.

AUGUST

Further modification to some small details on the dial, including the addition of dedication to Joan Page, long-serving College Secretary and generous benefactor of the College.

NOV 22

Firm order to Drings for stone. Foreman Chris Tanner very helpful (Fig. 3). Made valuable suggestion that the hemispherical surface on the top of the dial should be a separate piece. This would allow a hole to be drilled into the centre of the main body of the dial to accept a lewis pin for lifting purposes. Agreed. Realised I could not

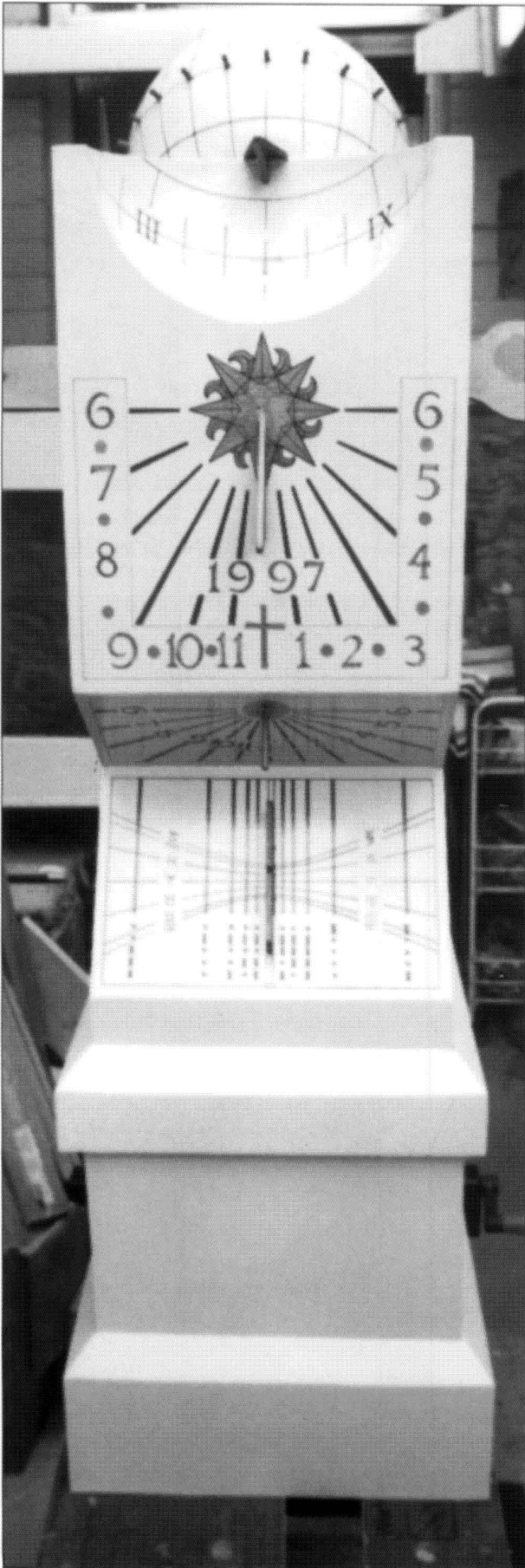

Fig.2 Full-size working model in wood, MDF and plaster, painted.

accommodate the stone at home because of difficulty of getting it into and out of my small workshop. Hit on the idea of using a defunct observatory at school. This had the advantage of a firm concrete central base which had been the support for a telescope. Building well away from rest of school. Great. Drings delivered the stone and we put it into place with the help of strong workmen. (Fig. 4). Resolved to look forward to the day when I could have my own drive-in workshop with overhead lifting gear.

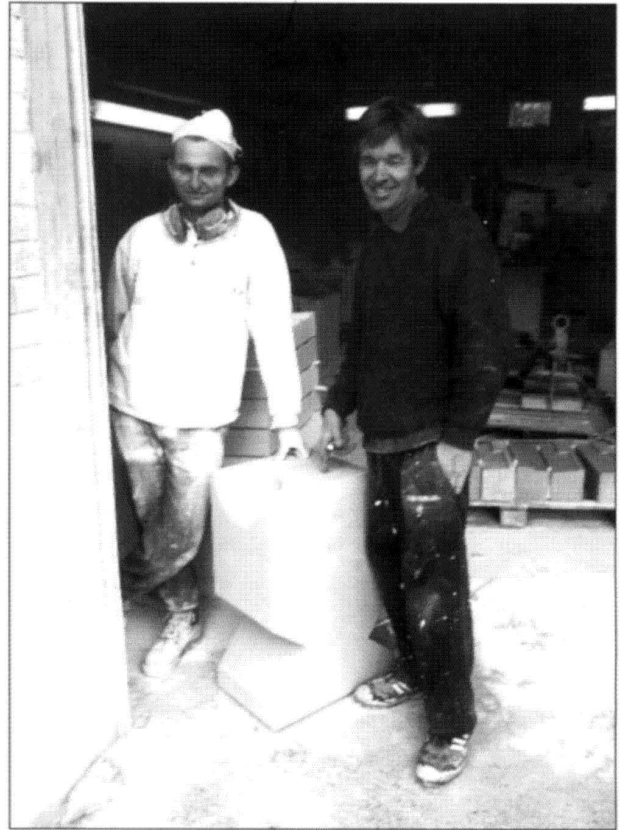

Fig.3 Stonemason foreman Chris Tanner of Drings, Bath and craftsman with completed body of the Portland stone dial.

12 DEC

Collected large model from Christ Church. Will be useful for lecture purposes at a later date.

1998 JAN

Started work on the dial. Wonderful stone, taking fine detail.

3 MAY

Spoke at BSS-AGM at Dunchurch Lodge, and described work to date. Took full-size working model for display.

23 MAY

Replied to anxious letter from Christ Church Treasurer wondering about progress, and wanting a date for completion.



Fig.4 Old observatory at Kingswood School, Bath which was used as a workshop, with the dial inside.

MAY - SEPT

Including most of Summer Holiday, continued work on the dial. Visitations from colleagues wondering what was going on.

SEPT

Correspondence with College about getting their Clerk of Works, Tony Morris, and assistants to do the foundation work. Dr Ian Wootton kindly agreed to establish the meridian direction for them, greatly preferring that for accuracy to their suggestion of using a compass.

27 OCT

(Week of half-term) Finished the dial. Much rejoicing. Started work on packaging for safe transport.

OCT 28

Finished packaging. Hired flat-bed truck and managed to get school workmen with tractor grab to load up the dial. Greatly anxious moments at times, but safely done in the end. Terrible weather.

OCT 29

Drove to Christ Church with various members of family in convoy homing in from Gloucestershire, London and Somerset to be conscripted workmen and field kitchen orderlies. Fine day, thankfully. Tony Morris and son plus others all raring to go with fork lift and chains. (Figs 5 and 6). All in place by 4 pm. (Fig. 7). Dial in shadow of

Meadows building. Alignment seemed OK from the few minutes of sunshine we had. Great jollity and much relief at the end. (Fig.8)

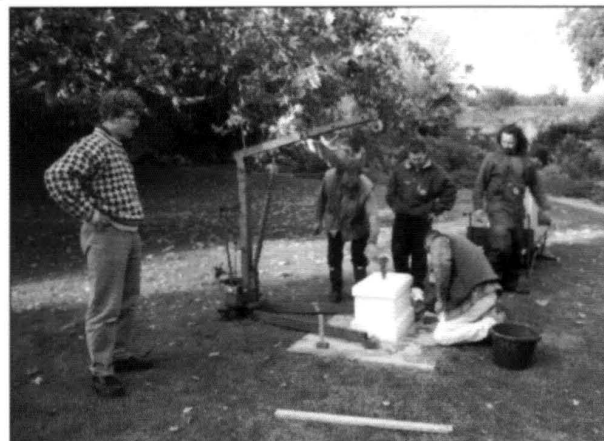

Fig.5 Positioning of the plinth in Pocock's Garden. The lewis lifting pin can be seen on top of the stone.



Fig.6 Hoisting the main dial with the lewis pin. The wood protective cladding is still on the dial. The Meadows Building is in the background.



Fig.7 Final positioning of the hemispherical top by David Brown and Tony Morris with his back to the camera.



Fig.8 The completed dial seen from the south west.

1999 11 JAN

Asked to help produce explanatory pamphlet. Did drawings and artwork. Pamphlet eventually produced by Oxonian Rewley Press Ltd.

I have discussed access to the dial with the new Treasurer, Hugh Richardson. His reply was that "the sundial is in one of our gardens to which the public does not normally have access. However, for those with a particular interest in seeing your sundial, the best course would be for them to apply to the Treasurer here and we can do our best to make arrangements which are convenient for a visit. This is largely a security and administration issue and we certainly would not want to dissuade anybody from visiting - provided it is a trickle rather than a flood!"

REFERENCES

- Philip Pattenden: *Sundials at an Oxford College*. Roman Books, Oxford 1979
 Eden & Lloyd: *The Book of Sun-Dials*. George Bell and Sons, London 1900
 Corpus Christi College *MS CCC 40, 152,430*.
 British Sundial Society *Bulletin* (various)

David M. Brown,
 21 Radstock Road,
 Midsomer Norton,
 Bath, Som. BA3 2AJ.
 E-mail DMBsundial@aol.com

THE SIMPLE SUNDIAL REPLIES TO HILAIRE BELLOC

So you would say a Sundial's fit to mock
 And put your trust instead in *Watch* or *Clock*?
 In me no *Spring* will break nor *Oil* grow thick
 Nor *Pivot* thin and quell the busy *Tick*;
 The Face of *Liquid Crystal* soon grows pale
 And *Battery's* reserves are bound to fail.
 My *Motion Work's* a shadow, which must run
 As silently and even as the **SUN**
 I'll stand without correction, year on year
 (Save only by *Aequation* known for here.)
 Though while there's cloud I'll rest, and all night sleep,
 When bright **SUN** lights me, then true time I'll keep

Andrew James

GRAECO-ROMAN SUNDIALS

PART II: CONICAL AND OTHER FORMS

ALLAN A. MILLS

Continued from Bull. BSS 2000 No.1 3-11

In part I it has been shown how three-dimensional stone dials based on the sphere - known as *hemicyclia* - were important in Greek and Roman times for indicating both time of day and time of year. However, even for a skilled mason a portion of a sphere is not easy to carve out accurately, so by the later Roman empire dials based on portions of a cone - the so-called *conical dials*³⁵ - had become the commonest pattern³⁶. Their advantage is that excavation of the cavity may be controlled with no more than a simple straightedge, whereas a spherical bowl requires a semicircular template for each size.

The invention of the conical dial is generally ascribed to one Dionysodorus, but being (with its variants) quite a common Greek name in antiquity this was the appellation of several Mediterranean geometers flourishing at the end of the 3rd century B.C. It has been suggested³⁷ that the existence of 3-D dials in public places could have stimulated a much more general knowledge of solid geometry than is observed at the present time.

Details of some conical dials not catalogued by Gibbs¹ are given in references 38 - 40.

CONIC SECTIONS

In theory⁴¹, a cone is generated by fixing a point on a straight line, and then moving the end of the line around a circle with the point acting as a pivot (Fig. 10). Strictly, this gives rise to two *right circular cones* - or *nappes* - joined at their apices and sharing a common axis. Menaechmus (4th century B.C.) pioneered investigation of the curves obtained on cutting such cones with a plane, and this research was continued and formalised by Apollonius of Perga (3rd century B.C.). His findings, and the nomenclature he introduced, are diagrammed in Fig. 10 and summarised below:

A cut perpendicular to the axis generates a *circle*.

A cut at an angle to the axis generates an *ellipse*, with an *eccentricity* depending on the angle.

A cut passing through both nappes generates a *hyperbola*.

A cut parallel to the generating line (and so never intersecting the second nappe) generates a *parabola*.

It will be appreciated that the parabola is a special and unique curve separating the general class of ellipses of

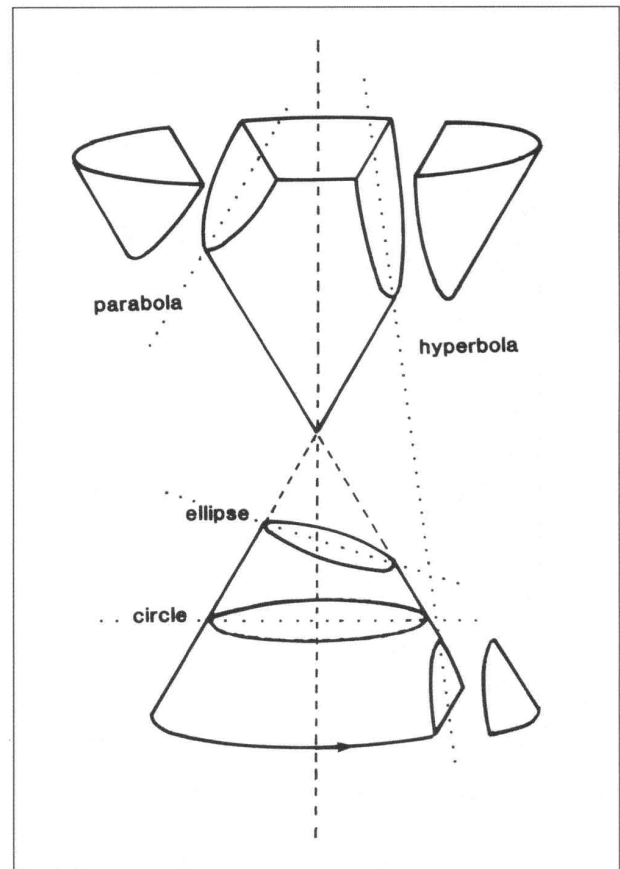

Fig. 10 Construction of cones and conic sections.

varying ellipticity from the general class of hyperbolae. Ellipses are always closed curves; hyperbolae are always open.

Finally, a cut along the axis produces an isosceles triangle, with the angle at its apex characterising the *solid angle* of the cone. However, geometers prefer to quote (as being more fundamental) the angle between the axis and the generator of the cone: I will refer to this as the *semi-apex angle* ω . The shape remaining when the top is cut from a cone is called a *frustum*.

CONICAL DIALS

The basic requirements of the conical dial follow from the underlying theory: the axis of the right circular cone must be arranged to point at the celestial pole (usually but not necessarily apex upwards), and a gnomon must be positioned so that its shadow-casting tip falls on this same axis. In practice, only a portion of a frustum of the basic cone is employed, the top of the stone being cut away along a horizontal plane to define the relative lengths of the

seasonal hours and allow access of sunlight (Fig. 11). A horizontal orientation for the gnomon is the shortest and most convenient, and was always used.

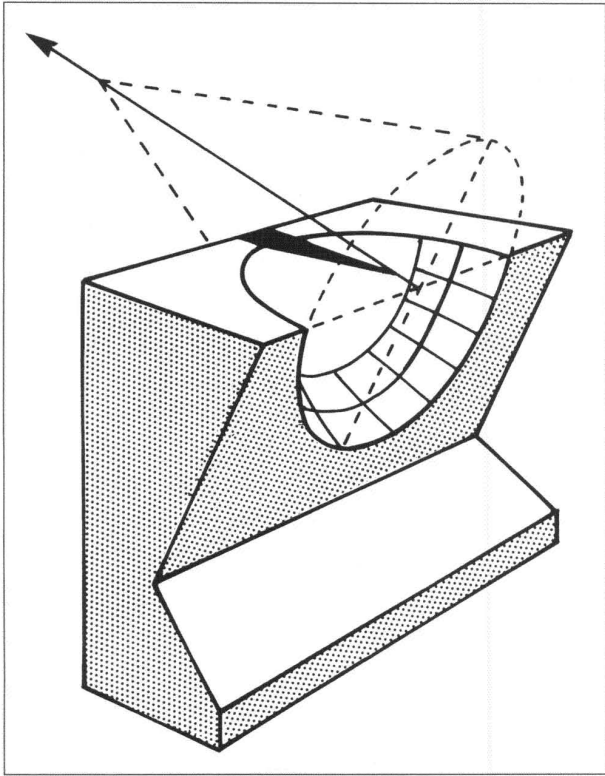

Fig. 11 Perspective diagram of a conical dial.

Under these circumstances the daily rotation of the Earth will cause the Sun to appear to move across the sky at right angles to the axis of the cone, the shadow therefore tracing portions of circles on the walls. Highest will be the winter solstice arc W, lowest will be the summer solstice arc S, and the equinoctial E will fall between them (Fig. 12). To aid visibility it was usual to cut away the stone below the SS arc at right angles to the axis, so the base of the conical aperture will also be part of a circle. The boundaries between the seasonal hours will, as for the hemicyclium, be represented by 1/12 divisions of all the daily arcs, but commonly represented only by the solstitial and equinoctial members. The points between the 6th and 7th hours will define a straight noon line, following the lowest generator of the cone to extrapolate to the base of the gnomon. The other hour lines will similarly be projections of the corresponding horary lines of the hemicyclium upon a conical surface, so in theory will be sinuous 'curves of double curvature on the cone' (see Part I). The relevant mathematics is detailed by Drecker²⁶.

In antiquity, the best makers of conical dials simply divided the solstitial and equinoctial arcs by trial-and-error with dividers, and then joined the triads of points with smooth curves (Figs 13 and 14). In Mediterranean latitudes these are so close to curves of single curvature (even when

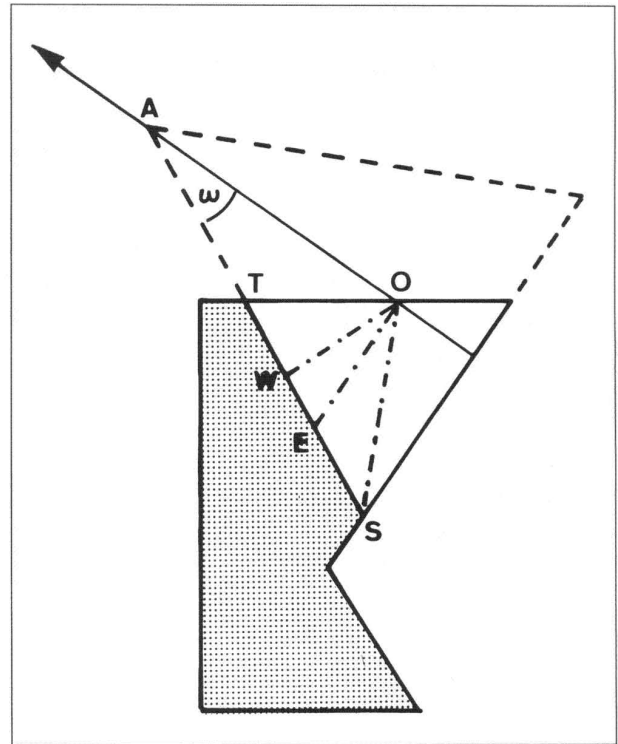

Fig. 12 Section through a conical dial, showing its mathematical construction.

distant from the noon line) that their true sinuosity was never appreciated. In fact, the portions below the equinoctial are so nearly linear that less careful makers were tempted to shorten the calibration procedure by simply dividing the lowermost SS arc and then drawing straight lines to the base of the gnomon (Fig.15). As the shadow tip never falls above the WS arc this erroneous construction appears to have been widely accepted. A possible connection with scratch dials has been elaborated elsewhere⁴.

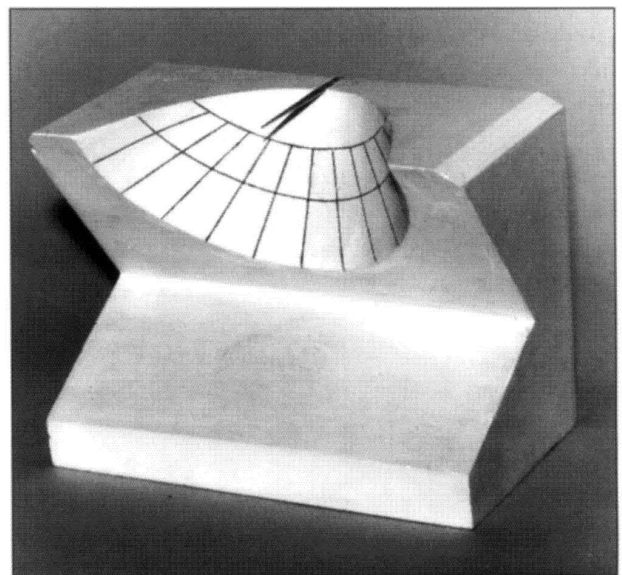

Fig. 13 The grid pattern of a conical dial. (A plaster model for 42°, the latitude of Rome. Semi-apex angle 30°).



Fig. 14 Conical dial found near Alexandria, at the base of Cleopatra's Needle. The Greek numerals labelling the hours are a rare feature, and may be a Byzantine addition to this Ptolemaic dial. Stone, 40 cm high x 43 cm wide. Semi-apex angle 37° . (British Museum no. 1936 3-9 1; Gibbs no.3086; Eden & Lloyd⁴³ p.32). Photographed 2 November, 1999.

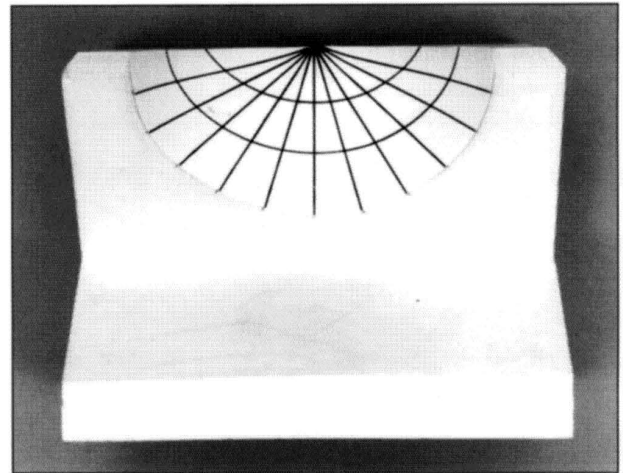

Fig. 15 Incorrect calibration of the conical dial.

THE APEX ANGLE

Two variables in the construction diagrammed in Fig. 12 are the distance AO from the apex of the cone to the point of the gnomon, and the semi-apex angle ω . Geometrically, the latter may vary between 0° and 90° , so what did Greek and Roman diallists use, and why?

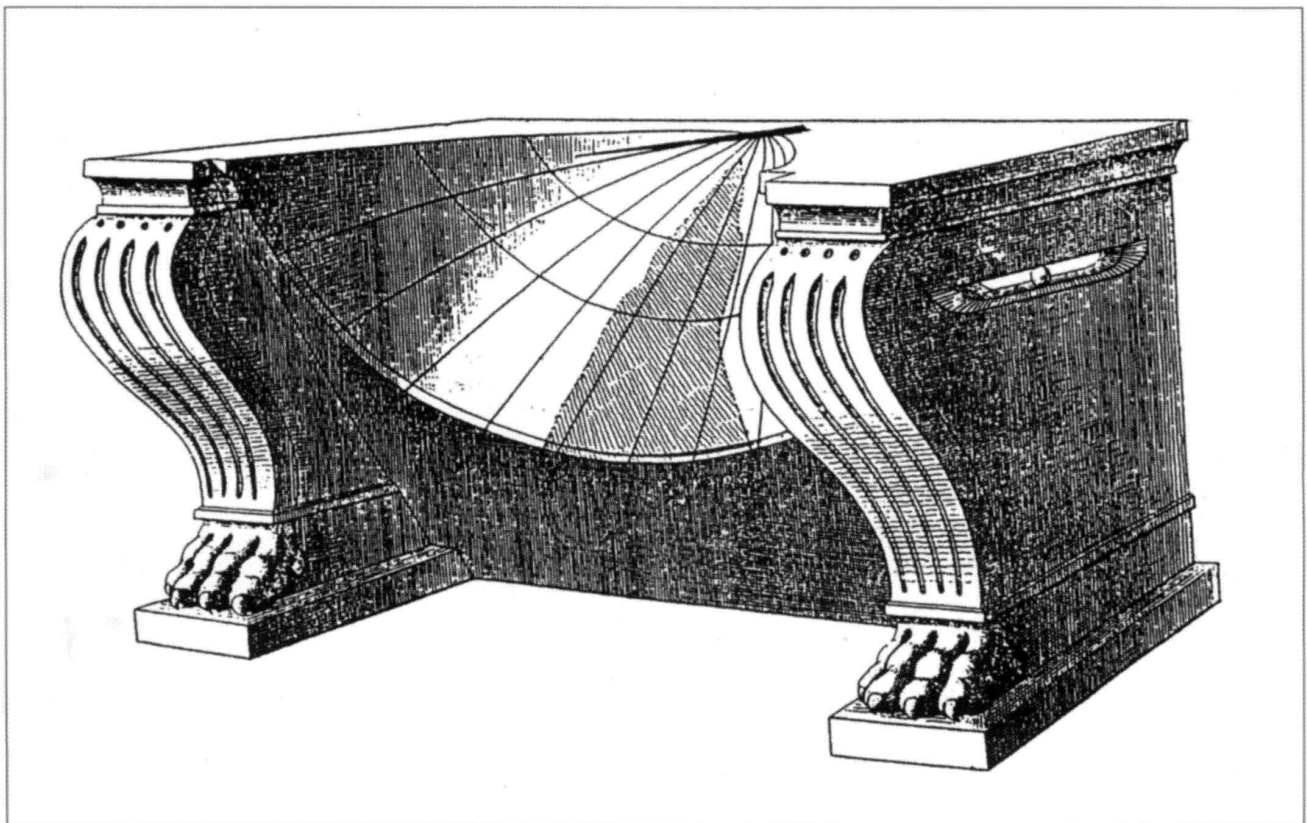

Fig. 16 Laussedat's reconstruction of a conical dial from measurements on the fragment indicated by diagonal shading. (Louvre, Paris.)

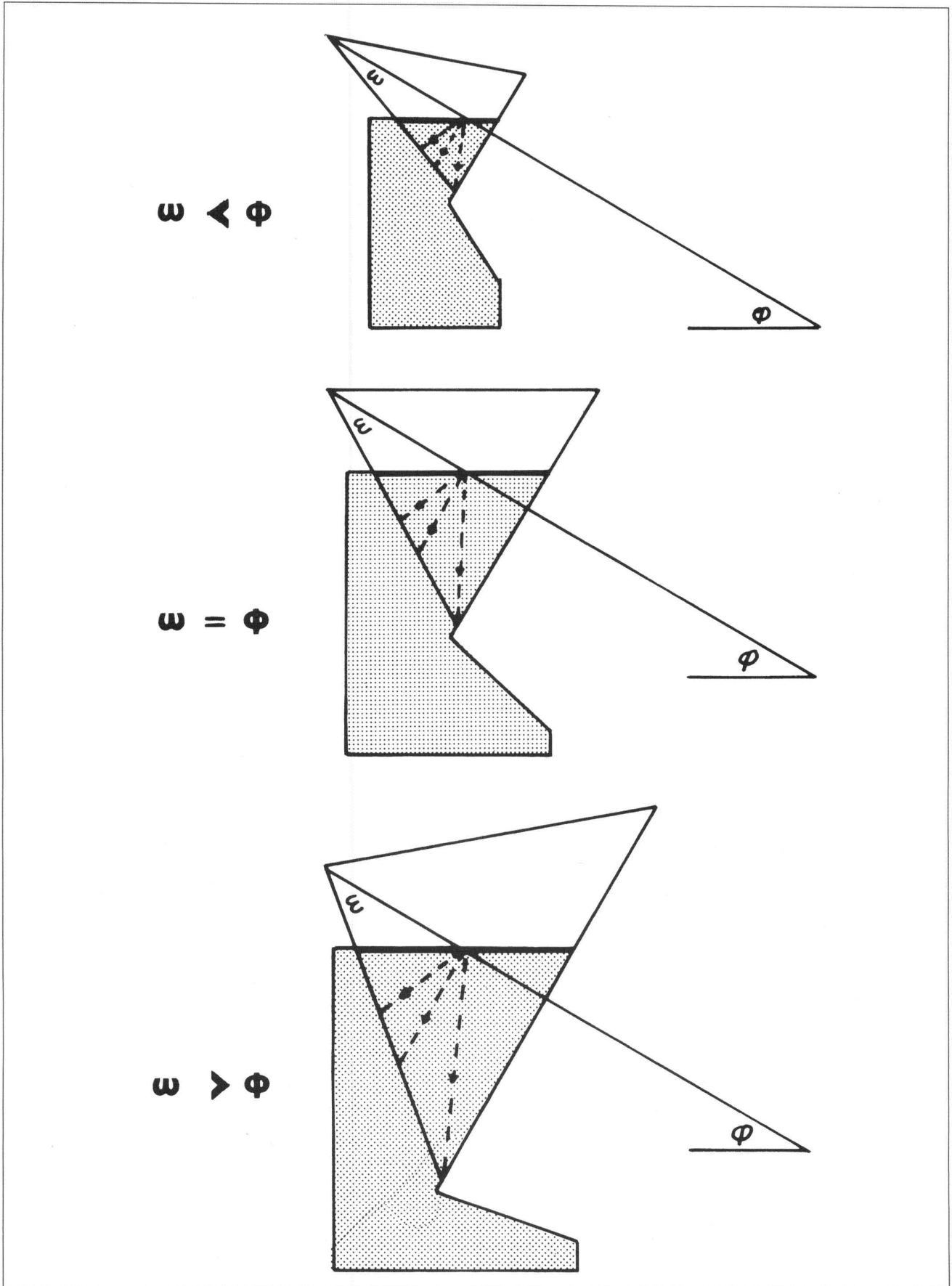

Fig. 17 The outline of the upper aperture of a conical dial (shown bold) is part of (a) an ellipse, (b) a parabola, (c) an hyperbola, depending on whether the semi-apex angle of the cone ω is less than, equals, or exceeds the latitude angle ϕ . Note how, for a constant value of AO, the size of the grid is least in situation (a).

No constructional details for making conical dials have survived, so hypotheses can only be based on data from archaeological artefacts. In a remarkable pioneering monograph published in 1872, Colonel Laussedat⁴² mathematically reconstructed an entire conical dial (Fig. 16) from measurements made on a fragment excavated from the ruins of Oumm el 'Amed in Syria⁴³. In the 2nd century B.C. this was a flourishing Phoenician city to the south-east of Tyre. Laussedat derived a semi-apex angle of $34^{\circ} 18'$ for the dial (which surely implies an unrealistic accuracy!) and identified it with the latitude of the site where the fragment was recovered.

Generalisation from a single example is invalid, but Gibbs¹ has computed the semi-apex angles of 56 conical dials recovered from around the Mediterranean. Values range from 8° to 51° , with pronounced clustering from 30° - 37° , five dials incorporating 34° . These latitudes do roughly define the Greek-dominated southern Mediterranean, so it is possible that one tradition was for makers to aim at a cone with a semi-apex angle equal to the latitude of the site. Fig. 17 shows that this leads to a parabolic outline for the upper aperture; cones narrower than the latitude angle result in portions of ellipses when intersected by a horizontal upper plane, and wider cones give hyperbolae. One might speculate that the unique nature of the parabola would appeal to the mathematical designer.

But what of the conical dials with semi-apex angles not included within the 30° - 37° range, some indeed being way outside the latitudes encompassing the Greek and Roman empires? Laussedat's work was soon followed-up by Rayet⁴⁴, and he discovered that two sundials found in Athens (lat. 38°) had semi-apex angles of 42° and $35^{\circ}30'$. However, he also computed that others recovered from Pompeii (but apparently designed for Rome, lat. 42°) had semi-apex angles of 13° , 20° , 25° , 32° , 36° , and 39° . These findings suggest that by later Roman times craftsmen no longer felt constrained to try to make $\omega = \text{latitude}$, but would be guided by the relative dimensions of the available block of stone and the aesthetic appearance of the final dial within its intended site. Gibbs¹ herself suggests that some diallists chose ω so that, in Fig. 12, $TW = WE$.

Conical dials with the apex of the cone pointing downwards ('antiborean') have been mentioned by Gibbs¹, Diels²⁶, and Ionescu-Carligel⁴⁵.

A SEASONAL-HOUR CONICAL DIAL FOR CENTRAL ENGLAND

The latitude of Leicester is 52.5°N , and this fixes the inclination of the axis of the basic cone. A semi-apex of the same value then gives rise to a peculiar and impractical

backwards-sloping dial that would be impossibly weak at the base.

Drawing mid-sections of dials of other geometries in the manner of Fig.17 suggested that a semi-apex of 20° , combined with a horizontal gnomon 3" long, would produce an overall shape (Fig. 18) comparable with the hemicyclium for the same latitude (Figs. 9 and 10). A frustum of such a cone with a base radius of 3.7" was turned from rigid foam, rubbed with a knob of margarine to fill the pores and prevent sticking, then fixed at the latitude angle in a waxed plywood mould. Pouring in liquid dental plaster and allowing it to set gave (after the locked-in foam cone had been excavated in fragments) a block with the desired conical cavity, the upper perimeter being part of an ellipse. A scale was generated by obvious geometrical constructions, and a horizontal 3-sided brass gnomon arranged with its tip at the point O. The resulting model is shown in Fig. 19. It has not yet been made the basis of a full-size 'villa' or 'forum' dial in stone.

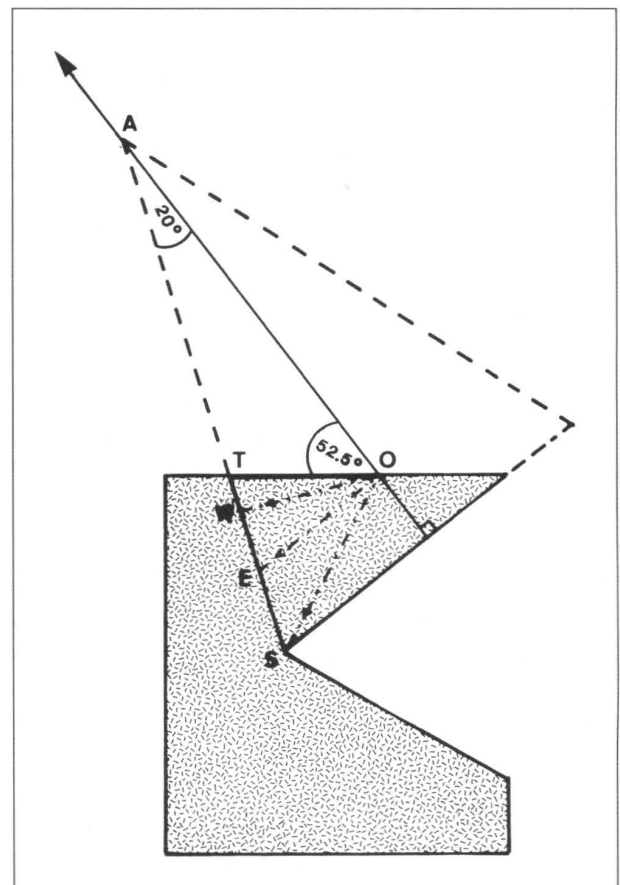

Fig. 18 A suggested conical dial for mid-England, with $\phi = 52.5^{\circ}$ and $\omega = 20^{\circ}$.

THE EQUAL-HOUR CONICAL DIAL

As with the hemicyclium, there is no reason why the conical dial surface should not be graduated according to the modern equal-hour system. It is considerably simpler,

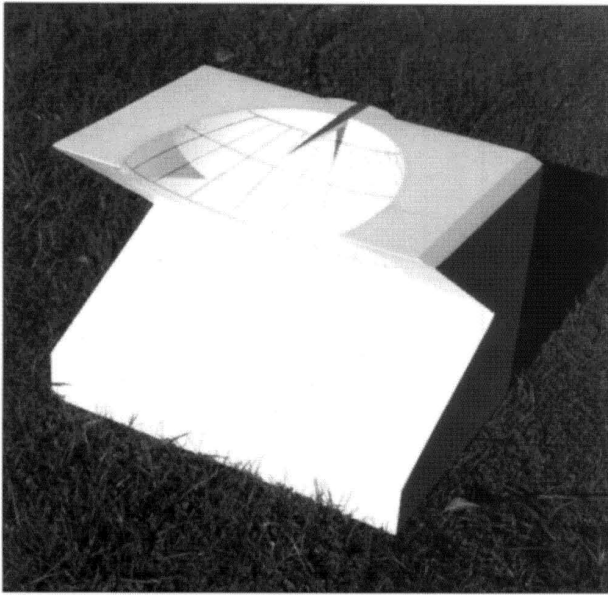

Fig. 19 Plaster model of a seasonal-hour conical sundial for a mid-England site, based on the section shown in Fig. 18.

for the hour lines take the form of straight lines on the surface of the cone spaced 15° apart and converging on the apex. An elegant stone dial of this nature has been installed at St Paul's City of London School⁴⁶.

OTHER SHAPES

Three-dimensional seasonal hour dials need not be limited to the sphere and cone: in theory, any regular figure of revolution may be employed so long as:

- Its axis is inclined at the latitude angle of the site, causing it to point at the celestial pole.
- The upper surface of the cavity is defined by a horizontal plane, corresponding to the horizon at the chosen site. This will automatically define the relative lengths of the seasonal hours.

The day-curves (e.g. equinoctial, WS and SS) will be parallel arcs of circles, and the hour curves will be projections of those in the hemicyclium.

Many surfaces of revolution could fulfil the above requirements but are difficult to lay-out and excavate, and there could be problems of accessibility to sunlight, visibility to a distant observer, inadequate separation of hour lines, and aesthetic appearance. It is therefore understandable that dials based on shapes other than the sphere and cone are very rare. A few cylindrical dials^{1,47,48}, inverted hemispheres^{1,43} ('roofed dials') and even an eyelet-hole scaphe⁴⁹ have been described. Two strange dials⁵⁰ with convex inner surfaces that are not figures of revolution appear to be aberrations.

Finally, as end-members of the series (where the radius becomes infinite) we have **planar** dials. In antiquity, these were generally vertical or horizontal. Their dial patterns have been considered elsewhere^{4,51-53}.

REFERENCES (continued from Part 1)

- J. Evans, 'The Material Culture of Greek Astronomy', *Journal for the History of Astronomy* **30** (1999) 237-307. Esp. pp. 243-247.
- D.J. de Solla Price, 'An International Catalogue of Scientific Instruments made before A.D. 1500: A Preliminary Report', *Vistas in Astronomy* **9** (1968) 41-42.
- O. Neugebauer, 'The Astronomical Origin of the Theory of Conic Sections', *Proc. Amer. Phil. Soc.* **92** (1948) 136-138.
- J. Livingston, 'The Mukhula, an Islamic Conical Sundial', *Centaurus* **16** (1972) 299-313.
- K. Locher, 'A Further Hellenistic Conical Sundial from the Theatre of Dionysos in Athens', *Journal for the History of Astronomy* **20** (1989) 60-62.
- M.S. 'A Conical Sundial: Review of Two Offprints', *Bull. BSS* **11** (1999) 14-16.
- The New Encyclopaedia Britannica*. 15th edn, 1991. Vol. 19, pp. 902-3.
- le Colonel Laussedat, *Mémoire sur un Fragment de Cadran Solaire trouvé en Phénicie*, Imprimerie Nationale, Paris 1872. Trans. by C.K. Aked as 'An Almost-Forgotten Fragment', *Clocks* **9** (1986) Part 5, 25-30.
- H.K.F. Eden and E. Lloyd, *The Book of Sundials*, Bell, London 1900. pp 36-38.
- G. Rayet, 'Les Cadran Solaires Coniques', *Annales de Chimie et de Physique* **6** (1875) 5th series, 52-86.
- C. Ionescu-Carligel, 'Contributions à l'étude des Cadran Solaires Antiques', *Dacia* **14** (1970) 119-137.
- C. Daniel, 'A Roman Renaissance', *Clocks* **22** (1999) 29.
- L. Janin, 'Un Cadran Solaire Grec à Al Khanoum, Afghanistan', *L'Astronomie* **92** (1978) 357-362. Trans. by R. Rohr as 'A Unique Greek Sundial' *Bull. BSS* 1990 No. 2 14-17.
- M. Tadic, 'The Roman Cylindrical Sundial in the Zemaljski Museum, Sarajevo, Yugoslavia', *Bull. BSS* 1991 No. 1 8-9.
- P. Gagnaire, 'The Scaphe of Carthage', *Bull. BSS* **11** (1999) 87-90.
- K. Locher, 'Two Greco-Roman Sundials from Alexandria and Dion', *Journal for the History of Astronomy* **24** (1993) 300-302.
- A.A. Mills, 'Seasonal-Hour Sundials for the British Isles', *Bull. BSS* 1990 No. 3 15-21.
- A.A. Mills, 'The Scratch Dial and Its Function', *Bull. BSS* 1992 No.3 5-8.

53. A.A. Mills, 'Seasonal-Hour Sundials on Vertical and Horizontal Planes, With an Explanation of the Scratch Dial', *Annals of Science* **50** (1993) 83-93.

SPHERICAL DIALS: AN ADDITIONAL NOTE

It has been discovered from the Sundial Register (Patrick Powers, Registrar) that there is an apparently genuine Roman part-spherical dial in the grounds of Hever Castle,

Kent. In this variant, the bowl is carved with its usual 'top' surface vertical, in the manner of Gibbs' plates 20, 21 and (especially) 23.

*Author's address:
Astronomy Group
The University
Leicester LE1 7RH*

THE NOON DAY STONE AT ST. MARTIN'S CHURCH, HORSLEY, GLOUCESTERSHIRE

TONY WOOD

The first visit to Horsley was not promising: the church was too new for scratch dials and there were no sundials either, nice clock and weather vanes though.

The following week the complete Gloucestershire collection of Church Trails¹ arrived through the letterbox. 'Horsley - St. Martin, note the ancient noon marker stone to the North of the tower'. I duly went and noted - in the snow with its problems of taking decent photos. The stone (Fig. 1) is twelve metres north of the west wall of the tower and bears the legend 'NOON DAY STONE'. Whether such a stone is unique I don't know but I haven't come across any mention of one previously.

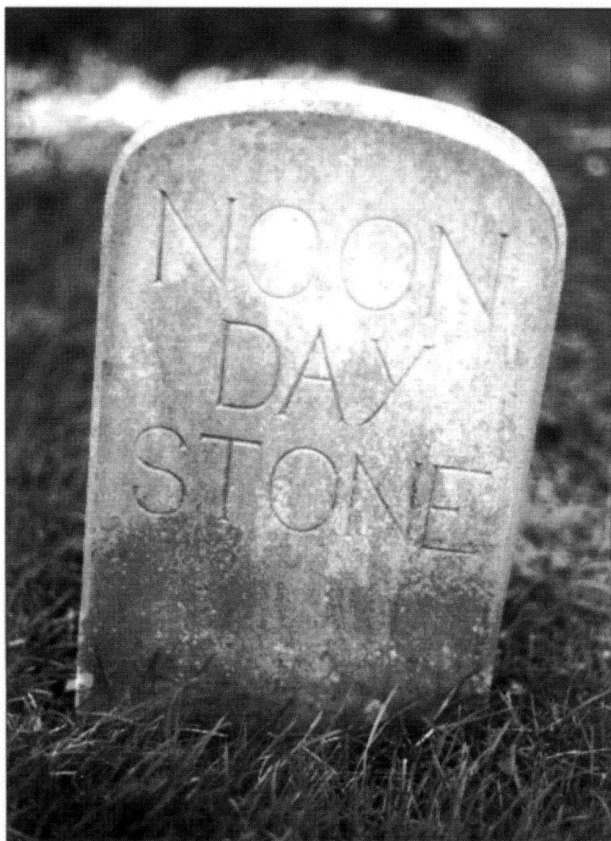

Fig.1 The Noon Day Stone

Peter Ransom had recorded it two years earlier but it had missed my edition of the Register. Meanwhile, Mme. Gotteland of the French Astronomical Society was asking for British Meridian Lines so details were forwarded to her in case our little stone qualified.

Meanwhile, details were emerging from various sources. Peter had pointed out that it was a modern stone and this was confirmed by the Church Warden who directed me to the stone mason who had carved it in 1997. He told me that a lorry had backed into the two-hundred year old original and the bits had been thrown away. He also assured me that the new stone was in the same place as the original.

I filled in a form for the Register and decided to check it out - timewise! Accordingly the next sunny day, with fingers crossed and hoping the forecast was correct, off I went with camera and watch to photograph the shadow crossing the stone. Considerably quicker than watching paint dry; once it hit the stone the sunshine fairly raced across its thickness. As the photographs show (Figs. 2 & 3), the stone passes from shadow to light in a little over a minute. The shadow is actually that of the tower north-west buttress (Fig. 4), the stone being slightly to the east of the tower wall line.

Taking into account the 2°W of longitude (8 minutes) and the equation of time (+13 minutes on February 6th) the expected time for the sun at meridian, local noon, would be around 12.21 GMT whereas the sun reached our stone at 12.13 GMT. My measurements were actually not that accurate as photography took priority; a sunny noon spell long enough is quite a rarity in February. Reading my watch only gives time to a completed minute and I realised some days later that my watch was fast by about two minutes. An error of a couple of degrees to the west is therefore a first estimate for the positional accuracy of the stone. Unfortunately we can't say that the stone is therefore set to give GMT, as its predecessor was in place long before the meridian was adopted in 1884.



Fig.2 The Shadow at 12.13 GMT



Fig.3 The Shadow at 12.15 GMT



Fig.4 The Shadow of the Tower Buttress

The next step is to wait for a sunny summer day and repeat the timings. I hope other noon stones may come to light, so to speak. As to whether it counts as a meridian line or not I will leave to the taxonomists. I do know, however, that our current listing of British Meridian Lines is about to be supplied from France.

REFERENCE:

1 Churches and Visitors Group of the Diocese of Gloucester. Church Trail No 10. *Nailsworth Ring of Churches*. Gloucester Diocesan Board, Gloucester, 1997.

*5, Leacey Court,
Churchdown,
Gloucester, GL3 1LA*

PRIVATE SUNDIALS

MARGARET STANIER

The main door of the Parish Church in my village is at the west end, and there is a porch outside it. The shadow of the ridge of the porch roof at around midday falls onto the north west corner of the square tower of the church. At solar noon at the summer solstice, the ridge shadow touches the grass of the churchyard just at the base of the lowest quoin-stone, and the whole north-west corner is in sunlight. A week later at noon the shadow has moved to the top of the quoin-stone; a week later it is at the top of the second stone, and so on, week by week, climbing the corner. The quoin stones are not all precisely of the same height, but larger-than-average balance out with smaller-than-average, and over the weeks, the count of the number of quoin stones in shadow at solar noon is close to the number of weeks since summer solstice. This is my private sun calendar and when eleven stones are shaded, I think: only a fortnight to the autumn equinox.

The end of a garden wall in my College casts a shadow on sunny afternoons of winter, onto the brick wall of a rather new building a metre or so inside the wall. The brickwork is laid all as 'stretchers', no 'headers'; and the vertical shadow of the wall-end moves horizontally along the brickwork, one brick per hour. When it has moved three bricks along: I know that it is teatime. My private sundial has told me so.

Such sun-and-shadow effects were of course unintentional and un-designed. The builder of our 15th century church porch did not deliberately make the porch roof of a given height and length *in order that* its shadow would reach the base of the corner at the summer solstice. The architect of the College building did not select the particular length of bricks so that a vertical shadow would traverse them in an hour on a winter afternoon. Architects, builders and their clients have no part in private sundials: the solar effects exist only for the pleasure of those who become aware of them.

All that is needed for 'discovering' or 'creating' private sundials and calendars is an architectural feature of distinctive shape, ('gnomon') so that its shadow is easily identified; and a surface bearing regularly-spaced lines: ('dial-plate'). These could be the mortar lines between courses of bricks or stones, or even the lines between boards of a wooden building. Or they could be the lines between the paving stones of a street or square, and the shadow could be that of the corner of a projecting balcony

above the street. If you are using the weekly (or daily) change in the altitude of the sun, as in the case of the climbing shadow after summer solstice, it is important to make the observations always when the sun is at the same azimuth. I shall probably find, when I have used my afternoon-dial for a while, that it is most reliable if read at a given altitude of the sun.

You too can 'discover' your private sundial. Buildings of any age, medieval to modern, will do, provided that there is some regularity and suitable spacing of lines in the structure. Modern buildings made of huge concrete blocks 3 metres by 2 metres are useless. So are many church walls of East Anglia, built of flint or of irregular stone 'rubble' picked from the fields by gleaning-after-the-plough. A fixed architectural feature on the same or a different building is the best object for the 'gnomon'. Trees and their shadows change shape with the seasons, and get blown about: not recommended.

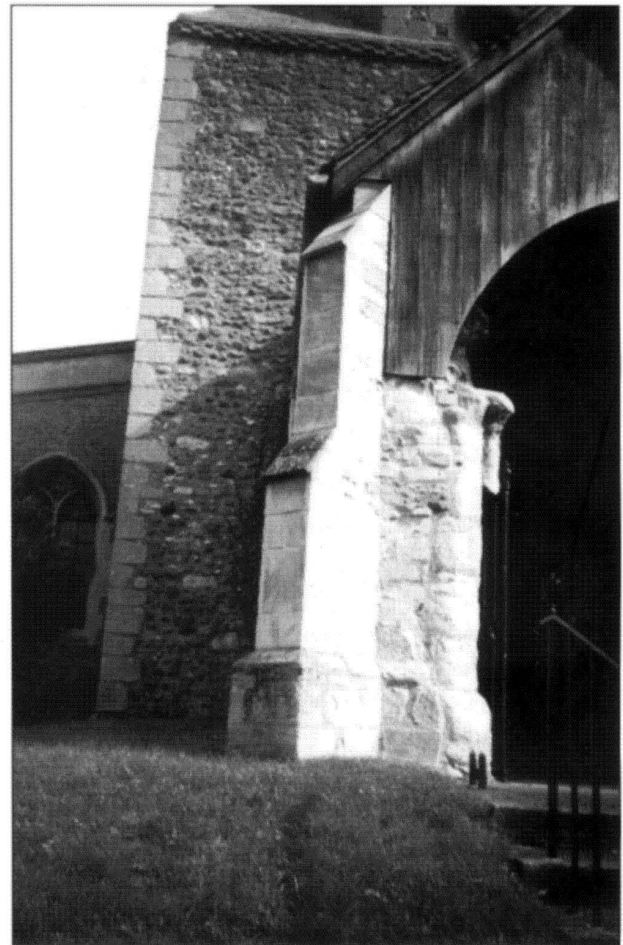

21st September 1999: On the 13th stone from the bottom

Standing in marked contrast with these incidental, unplanned and unforeseen sunshine-and-shadow effects on completed buildings is the precision and foresight with which many buildings are initially laid out. Their placing and orientation on the building-site is often a matter of great care, and solar considerations may then be a determining factor. This may be necessitated by ritual or religious observance for which the building is to be used. Or perhaps, as at Stonehenge and Maes Howe, it is a matter of the fixing of an annual calendar-date, for a prehistoric agricultural community. Tradition and liturgical requirements determine the (approximately) east-to-west orientation of many church buildings, from the Middle Ages onwards. In present-day buildings the comfort of a dwelling, its warmth or coolness, may depend on its aspect and the precise position of its doors and windows. But the solar effects due to the original placing of the building are not the concern of the private-dial discoverer. He needs to know simply which is the south side of the building: south, west and east sides are the most promising routes of discovery; he will get little joy from the north aspect.

Few private dials are ever reported or documented. There must be hundreds of such features out there awaiting discovery, so they have no scarcity value; they are irrelevant to the building's purpose, and have no part in the architect's intentions. But to those who discover and regularly notice them on sunny days, they give a secret joy.

ACKNOWLEDGEMENT:

I thank Professor Alan Smith who drew my attention to reports of solar effects on church buildings in Virginia, Wiltshire and Pisa.



*2nd October 1999: Nearly two stones higher than
21st September*

SOME MASS DIALS IN NORMANDY

JOHN LESTER

In his book, "Scratch Dials, their Description and History" (1929) Dom Ethelbert Horne writes: "In all probability the Normans brought the Scratch dial with them from Normandy", and adds that they appear in construction and design to be exactly the same as ours. He lists churches in Normandy which carry Scratch dials: "Marigny, some four miles north of Bayeux; Subles, south west of the same city; Manvieux, not far from Arromanches; Treves, north of Samur (sic), and Fontaine Henry, about four miles to the south of Courseulles." Of these we must discount Treves since it is in Anjou rather than Normandy.

All the other places mentioned are quite close to the invasion beaches of World War II and must have been at great risk of destruction. I was interested to find out how

many had survived and to look for differences between Norman mass dials and our own. The first visit was to Subles where the first impression of the church was of a building too recent to carry any. It was a pleasant surprise therefore to find no less than three dials on buttresses along the south wall. Marigny was elusive in spite of a map, and its church even more so. Enquiries in the local bar elicited the information that the church had been destroyed in the war; hardly surprising as it lay immediately behind Gold Beach. At Manvieux the church looked unscathed and unrestored and yielded two dials, one of them inverted. Further east two dials were found at Fontaine Henry, one in the keystone of a blocked up doorway, the other hiding behind a modern drainpipe.

DIAL.	SKETCH. (Not to scale)	POSITION.	HEIGHT above G.L.	RADIUS.	GNOMON HOLE.		ASPECT	ANGLES of RADII. NOTES.
					DIA.	DEPTH		
SUBLES 1		S. WALL, WEST BUTTRESS. 12	1830mm	40mm	10mm	BLOCKED	5° E of S.	30, 55, 102, 137, 156. (Sketch shows how angles are recorded.)
SUBLES 2		S. WALL, 2 nd BUTTRESS from WEST. 17	1580mm	45mm	8mm	10mm	5° E of S.	28, 49, 110, 128, 141, 162. Gnomon hole beneath dial.
SUBLES 3		S. WALL, 3 rd BUTTRESS from WEST. 26	1850mm	85mm	OBLITERATED		5° E of S.	0, 15, 27, 40, 57, 74, 92, 108, 125, 137, 158, 168, 180.
MANVIEUX 1		S. WALL to LEFT of 4 th BUTTRESS from EAST. 19	1870mm	95mm	10mm	40mm	37° W of S.	30, 55, 113, 143. DEDICATION: ST. REMY.
MANVIEUX 2		S. WALL by 2 nd WINDOW from EAST. 44	2990mm	95mm (E)	10mm (E)	?	37° W of S.	190, 228, 270, 307, 335. [or 10, 48, 90, 127 155 if DIAL WERE UPRIGHT]
FONTAINE HENRY 1		S. WALL, to LEFT of BLOCKED DOORWAY. 70	3190mm	90mm (E)	15mm (E)	?	22° W of S.	OBLIQUE VIEW ONLY - ANGLES NOT MEASURED
FONTAINE HENRY 2		ON KEYSTONE of BLOCKED DOORWAY. 71	2950mm	120mm (E)	10mm (E)	?	22° W of S.	15, 44, 59, 75.
BAROU 1		ON S. WALL of TOWER. 2	815mm	65 mm (AVERAGE)	10mm	12mm	18° E of S.	No RADII. XI cent.
BAROU 2		S. WALL of NAVE near EAST END. 49	1540mm	70mm	5mm	8mm	14° E of S.	40, 52, 63, 113, 128, 147, 163, 205. Very spidery lines.
BAROU 3		S. WALL & EAST END of CHANCEL. 88	1930mm	100mm	10mm (E)	?	13° E of S.	OBLIQUE VIEWS ONLY - ANGLES NOT MEASURED.
NORREY		To RIGHT of BLOCKED PRIEST'S DOORWAY. 72	1450mm	47mm	5mm	8mm	3° E of S.	0, 52, 90, 140, 166, 213, 270, 315. Lines irregular. XI Cent.

Fig. 1 Mass Dial Records

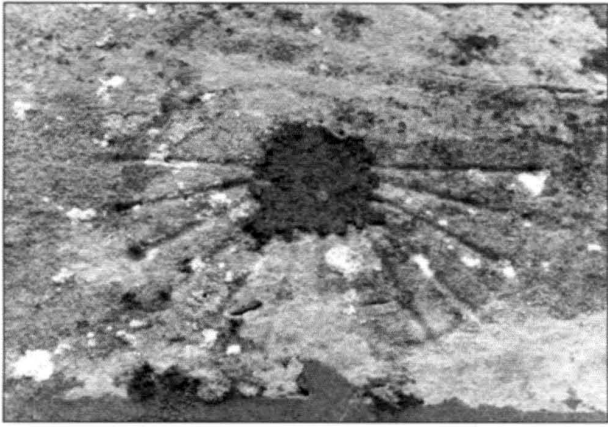

Fig. 2 Subles 3

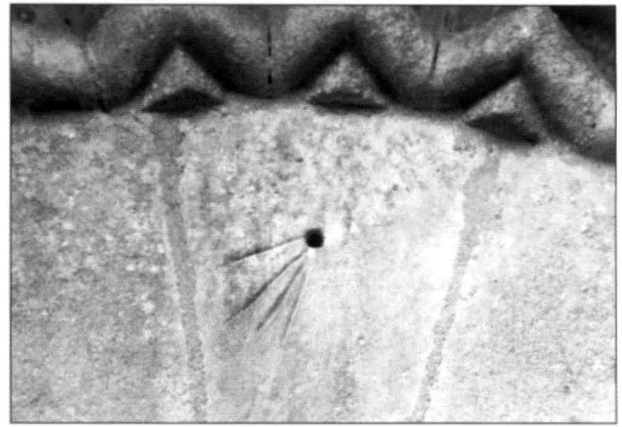

Fig. 5 Fontaine Henry 2

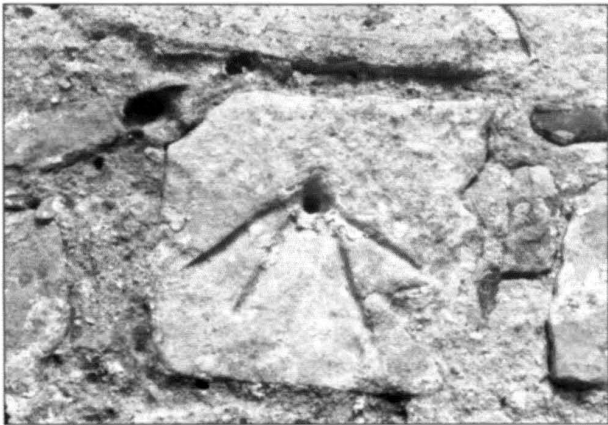

Fig. 3 Manvieux 1

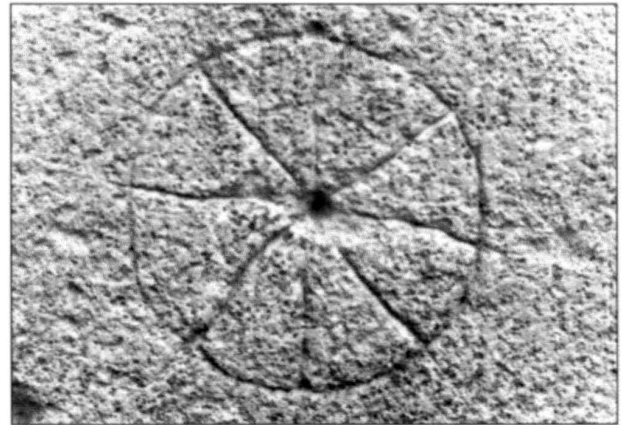

Fig. 6 Norrey



Fig. 4 Fontaine Henry 1

On another day, two other old churches were visited at Barou en Auge and Norrey en Auge in the area to the east of Falaise. At the first, three dials were found and at the second, one. Of the three at Barou, one was also hidden behind a modern drainpipe.

Unlike English churches, rural churches in Normandy often lack any information about their history or even their dedication. There is seldom even a notice board outside, there are certainly no helpful leaflets or church guides and there never seems to be anyone about who might be able to answer questions. The information in the accompanying table (Fig.1) is therefore less complete than it ought to be and in any case from this small sample of the many old churches in Normandy it would be unwise to try to draw any firm conclusions. Perhaps our French counterparts could be persuaded to organise a mass dial safari in this area if they haven't done so already.

*Author's address:
24 Belvidere Road
Walsall
West Midlands, WG1 3AU*

THE GATTY FAMILY - PART 1

MIKE COWHAM

‘WATCH, FOR YE KNOW NOT THE HOUR’

Inscribed by Mrs. Gatty on the base of the sundial in Ecclesfield churchyard.



Fig. 1. The Sundial in Front of Ecclesfield Church.



Fig. 2. The Sundial at Ecclesfield as illustrated in ‘The Sun-Dial Book.’

Anyone with an interest in sundials will be well acquainted with ‘The Sun-Dial Book’ written by Mrs. Alfred Gatty. To us she is revered and has become almost ‘The Goddess of Sundials’.

Margaret Gatty was a remarkable woman, belonging to a remarkable Victorian family, several of whom attained fame in their own rights. She had many interests and wrote books on several topics, showing her agile mind and wide awareness of the world around her.

I have spent some time researching into this family and have become intrigued by their origins, their family life, their knowledge and their achievements. In this article I am bringing together, in fairly concise form, a history of the Gatty family, with particular reference to Margaret and her interest in sundials. I hope that the reader will not be too bored by the parts that do not directly relate to sundials, but these items help to show what a talented family they were.

ORIGINS

The name Gatty, or Gatti, is probably of Italian origin. Several Gattys are known to have arrived in this country in the 18th Century. There were several well-known barometer manufacturers of that name. I do not know for certain whether Alfred Gatty was descended from any of these, and further research into his roots is necessary.

The origins of Margaret Scott’s family are better known and documented. Her father, Rev. Alexander John Scott, DD was born in 1768. A grandfather of his had fought with Bonnie Prince Charlie at the battle of Culloden. Alexander Scott was educated at Charterhouse and Cambridge. He was an accomplished linguist and was employed in the Navy as an interpreter for Sir Hyde Parker, who gave him the title ‘My Foreign Secretary’ due to his language and writing skills. In his early career he was badly injured by an ‘act of God’ when he was asleep on board a ship. He was hit by a bolt of lightning which also ignited a store of gunpowder nearby. The result was that several shipmates were killed, and Scott was badly injured. He lost his front teeth, and suffered pain from his injuries for the rest of his life. Parker lent Scott to his colleague Lord Horatio Nelson, under whom he served on the Victory as Chaplain and ‘Foreign Secretary’. His most memorable hour was at the battle of Trafalgar, (21 October 1805), where Nelson was mortally wounded by a French sniper’s bullet. Scott says that the blood and gore of the battle sickened him. Due to his nausea was hardly able to administer to his dying shipmates. When Nelson fell, Scott and fellow officer Burke cradled the dying man in their arms trying to comfort him. Nelson’s last words to Scott were ‘My God and My Country’. Nelson died in his arms. Nelson was Scott’s great hero, and had been his personal friend. He was also a national hero throughout Britain for the success of the battle at Trafalgar. Nelson had asked Scott that if he should ever marry, he would name his first child after him. Scott was deeply affected by his experiences on board the Victory, and shortly afterwards he retired from the Navy

taking up a living at Burnham in Essex. In 1816 he was appointed, part time, as chaplain to King George III (by that time quite insane), a position that he retained until the King died.

Scott spent the rest of his life as a country parson, being jointly vicar of Southminster, Essex and Catterick, North Yorkshire. Shortly after leaving the Navy he fell in love with Mary Ryder, only half his age. As her father would not agree to her marrying such an old man, the couple did the unthinkable for a man of the cloth and eloped. They were married secretly, managing to hide this for a while from their friends.

The couple had two surviving children, Horatia and Margaret. True to his promise to Nelson, his first child had been called Horatia. Margaret Scott was born at Burnham rectory on 3 June 1809. A third child, a son, was born almost two years later. He had an unfortunate demise, being accidentally smothered by his nursemaid, who, when sleeping with the baby, rolled over onto him. The mother died a few months later on her 26th birthday, leaving the two girls of four and two in the care of their father.

Horatia and Margaret made many visits to their maternal grandfather, Thomas Ryder, who was master of Charterhouse. Generally their summers were spent in the country with their father, and the winters with their grandmother in the precincts of Charterhouse. Following in their father's footsteps, both sisters became good linguists, particularly in French and Italian. At the age of 10, Margaret spent much time in the Print Room of the British Museum. She was encouraged to visit there by her uncle William Ryder, who taught her to draw. She became an accomplished artist and frequently sketched in pencil. Later she took up working on etchings, mostly of trees and landscapes, copying many of the prints that she had seen in the Print Room. A set of her etchings is still held in the British Museum.

In 1817, the Scott family moved to the parish at Catterick in Yorkshire, where the two sisters were brought up and educated by their father. Horatia became a classical scholar, and Margaret more of a linguist. Margaret was particularly influenced by German literature, quickly becoming fluent in German, and for some time she wrote her diary in German, in Gothic script. She became an excellent calligrapher and also illustrated on vellum. Her other main talent was music, and she was an accomplished pianist.

She started what was called 'The Black Bag Club'. The black bag was used to collect stories and poems from her friends, and these were read aloud to a group of them once

each year. It is through these humble beginnings that we see her writing talents forming. At the age of 17, she made an original translation of Dante's *Inferno*.

Her youth was spent mostly in the area around Catterick. The church there had a sundial over the door, and she saw several other dials in the area. From this time she would start to record their mottoes.

MRS. GATTY

Margaret met Alfred Gatty at the vicarage in Catterick where he had been invited by Rev. Alexander Scott. Alfred had been born 18th April 1813 (Easter Day) at 3 Angel Court, Throgmorton Street, London, the son of a solicitor. He was educated at Charterhouse, Eton and Exeter College at Oxford, receiving his BA in 1836 and MA in 1839. He had been ordained in 1837. When he began to show an interest in Margaret, her father tried to discourage them. He did not want his daughter to marry a poor clergyman, particularly one without his own parish. Eventually he relented and the couple were married at St. Giles in the Field in London, 8 July 1839. This church still stands, close to the junction of Tottenham Court Road and Oxford Street. It is now dwarfed by the surrounding buildings, including Centre Point. The church register records their marriage. Alfred Gatty is described as Clerk - residence, The Temple. His father, Robert Gatty, is described as a solicitor. Margaret Scott is shown as a spinster, residing in Bedford Square, (where she had been staying with the family of Sir Nicholas Tindall, Lord Chief Justice of England). C. T. Ripon (Bishop of Ripon, Charles Thomas Longley) performed the ceremony. The witnesses were A. Scott, (Margaret's father - signed in a very shaky hand), N. Tindall, Juliana Symonds, Jane Fisher, and Juliana Reynolds. The newlyweds spent a couple of days, possibly in Hampton, before taking the 40-hour steamer journey on 'The Monarch' from London to Leith. Margaret even noted a dial in Leadenhall Street on her way to the steamer. Whilst on their wedding tour they heard that uncle Thomas Ryder had died, leaving the living at Ecclesfield, near Sheffield, vacant. This living was offered to Alfred Gatty, which he was pleased to accept.

They arrived with maid Bella at Ecclesfield in September. **Fig. 3.** They found that the church was in a poor state of repair and was in need of certain modernisation. According to Alfred Gatty's writings, the parishioners were 'rather rough folks with barbaric habits which included bear baiting and cock fighting'. Alfred was determined to make significant changes, but first he and his new wife had to win the respect and friendship of their parishioners. It was therefore some years before he embarked on making the changes needed in their church. The parish of Ecclesfield

was at that time, one of the largest in Yorkshire, and was a major responsibility for a young and inexperienced vicar.

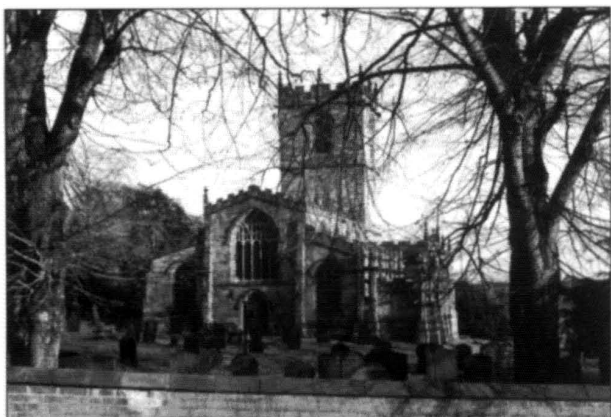

Fig. 3. The Church at Ecclesfield, 'The Minster of the Moors'.

Over the next few years, the Gattys had eight surviving children. These were: -

Margaret Scott (Madge)	1840	Married F. P. Smith.
Juliana Horatia (Julie)	1841	Married Alexander Ewing (Rex).
Alfred Alexander	1843	Died in infancy.
Reginald Alfred	1844	
Horatia Katherine	1846	Married Thomas Bainbridge Eden.
Frances (Dot)		
Alfred Scott	1847	
(Doctor Brownie)		
Undine Marcia (Diney)	1848	Married Rev. W. Ward.
Stephen Herbert	1849	
Charles Tindall	1851	
Horatio Nelson	1855	Died in infancy.

Notice that several children were named after Nelson, and after Margaret's father Alexander John Scott. Charles Tindall was named as a tribute to their friend Sir Nicholas Tindall.

Margaret like her father before her decided to educate her own children. She was a great storyteller, and would sit in front of the fire with her children around, telling them tales, many of which were of her own invention. The boys were eventually sent to school, but the girls learnt everything from their mother. In turn, each child would help to educate the younger siblings.

The nursery was a happy place, always full of fun, of music and jokes. The leader of all of this was not Madge, the eldest, but Julie. She had a talented imagination, manifested later in her life. She would make up stories and often

organise the performance of a play for the others in the nursery. Julie had by this time taken over from Margaret as storyteller of the family.

In spite of the duties of bringing up her large family, Mrs. Gatty had many interests. She was very fond of flowers, cultivating some scarce plants in the vicarage garden. She was interested in astronomy; and she was particularly keen on chloroform and its benefits, persuading the local doctor to use it on his patients. She experimented with eating fungi, and lived to tell the tale!

After the birth of her seventh child, Undine, her health started to deteriorate. She had developed bronchial problems, which the harsh Yorkshire climate would worsen. In the winter of 1848/1849 she and her son Reginald Alfred stayed about 5 months in Hastings where the climate was less severe. While there she made the acquaintance of a local doctor who had an interest in seaweeds. He lent Margaret his copy of *Phycologia Britannica*, which she studied with relish. She would frequently walk on the beach picking up specimens and sketching them. Her main interests here were zoophytes and polyzoa. By the time that she returned to Ecclesfield, seaweeds had become her new passion. She made frequent trips by train to the Yorkshire coast to collect specimens. Her daughter Dot was also a keen collector, becoming in turn quite an authority on them.

MRS. GATTY'S BOOKS

Both Alfred and Margaret Gatty wrote several books. Margaret's first was 'The Fairy Godmothers' published in 1851 when she was 42 years old. In 1855 her book 'Parables from Nature' appeared, for which she drew her own illustrations. These were short stories for the young usually containing a moral lesson. Further series of 'Parables' were released in 1857, 1861, 1863 and 1870. Later editions of 'Parables' were illustrated by well-known artists, with editions still being printed well into 20th Century.

In 1858, she published 'Aunt Judy's Tales'. The character, Aunt Judy, was really modelled on her daughter Julie, storyteller in the nursery, and the tales related were similar to those that Julie would have made up. 'Aunt Judy's Tales' was followed in 1862 by 'Aunt Judy's Letters'.

During the year 1859, a friend, Dr. Wolff, stayed at Ecclesfield. He was quite a character, and had travelled widely in many parts of the world. The Gatty family assisted him in writing his autobiography, published in 1859. He would dictate continuously for hours at a time. Margaret, helped by Dot, would try to write down

everything that he said. In return for their efforts, Dr. Wolff taught the children Hebrew.

In 1862 Margaret's most important scientific work appeared. This was 'A History of British Seaweeds', in two volumes. In her work she was supervised by Dr. William Harvey, professor of botany at the University of Dublin. This work became one of the major textbooks on seaweeds and was still in use in some botanical departments a century later, although, by this time, many of the species had long since been reclassified. Margaret had become an expert on British seaweeds. She later had the honour of having two newly described species named after her. The first was a species of algae, *Gattia pinella*, and the second a sea worm, *Gattia spectabilis*.

Dr. Harvey gave a description of Margaret, in the following words:- "She is slight, tallish and intellectual looking and withal quiet; at least as yet nothing very mercurial has broken out. But there is evidently the mercury below the surface, and I can quite fancy her blazing up - when strongly excited".

Margaret also met Lord Tennyson, introducing herself to him. Tennyson had admired her writings, particularly 'Parables', and he and she became friends.

Margaret was now writing one new book each year. She had always used the same publisher, her friend Mr. Bell, who was nicknamed Tinkler (probably by Julie). In Margaret's documents she often drew a bell instead of writing his name. The small Sancte bell at Ecclesfield, used to call a parson to his duties, was locally known as 'Tom Tinkler'.

In 1868 she was persuaded by Bell to edit a new monthly magazine for children that he was to launch. He suggested its title, 'Aunt Judy's Magazine'. As editor, Margaret was paid the sum of £10 per month and 10/- was paid per page for contributions to it. This periodical proved to be the ideal medium for Julie's emerging talents and she regularly wrote stories for it. The other children too had the opportunity to show off their talents within its pages. Alfred Scott was a musician, and regularly composed the music for songs in the magazine. Sometimes he, or one of the other children, would provide the verse. Charles Tindall also wrote occasionally. Another contributor was Eleanor Lloyd, better known to sundiallists for her contribution to 'The Book of Sun-Dials'. Articles for Aunt Judy's Magazine came from many sources, often from quite famous authors of the day. The Magazine was to continue past Margaret's death, until 1885, edited by Horatia (Dot) and Juliana (Julie). It was never the complete success that Bell had hoped for,

returning a profit in only two of the years that he sponsored it. Eventually it was sold to another publisher and soon afterwards disappeared. However, Aunt Judy's Magazine had its followers, and its successes. Rudyard Kipling claimed that he owed a lot to a bound volume of it, and in particular, to Juliana's interesting stories.

In 1868, Margaret pleaded with her young readers to subscribe to a cot for sick children at Great Ormond Street Hospital. **Fig. 4.** Contributions were received from many children, from pennies upwards, and £1000 was presented to the hospital to endow a cot for girls. This was the first such endowed cot at the hospital. In 1876, a further cot for boys was established, and by 1885 ten cots had been endowed in various childrens' hospitals. Although endowed 'permanently', these cots disappeared after the introduction of the National Health Service in 1947. In April 1881, Aunt Judy's Work Society was formed. Its purpose was to make clothes for patients in the Hospital for Sick Children. The response was so good that local groups were set up for making clothes for hospitals each in its own area.



Fig. 4. Aunt Judy's Cot at Great Ormond Street Hospital.

Margaret's health never returned, her last ten years becoming increasingly miserable. Her writing had deteriorated owing to paralysis. **Fig. 5.** By 1866 she was seriously ill and never free from pain. Her last two books,

'A Book of Emblems' and 'The Book of Sun-Dials' appeared in 1872 only a year before her death. 'The Book of Sun-Dials' was mainly a collection of mottoes that she had made since her childhood. To add to her own mottoes were others collected by friends and correspondents, and the large quantity of foreign ones had been collected by her 'young friend' Eleanor Lloyd during her travels, mostly in southern France and northern Italy. Margaret's illness eventually made writing difficult. After her right hand had failed, she used the left for a while, and eventually she could only dictate her thoughts. Her brain, however, remained fully active until the end. 'The Book of Emblems' and 'The Book of Sun-Dials' were produced mainly through the efforts of Horatia (Dot).

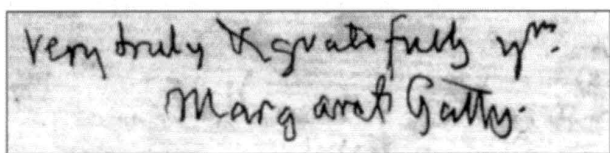

Fig. 5. Margaret Gatty's Signature.

Margaret Gatty died at Ecclesfield, aged 64, on 4 October 1873, and is buried in a family grave on the north side of the church, next to the vicarage gate. Fig. 6. A short memoir was published in Aunt Judy's Magazine written by Juliana. In 1874 a stained glass window known as The Parables Window was installed in the south transept of Ecclesfield Church in her memory. Fig. 7. More than 1000 children, readers of Aunt Judy's Magazine, subscribed to a marble tablet that was set in the chancel of the church.

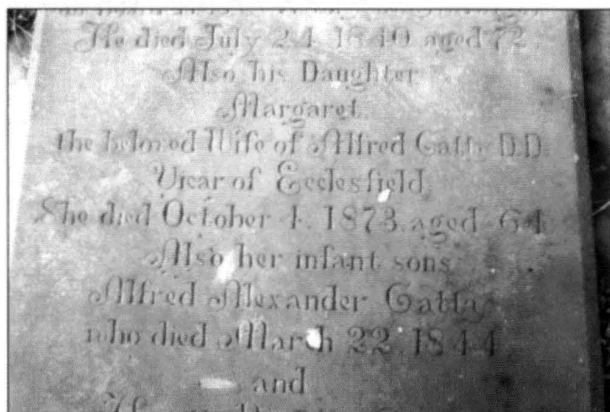

Fig. 6. Margaret Gatty's Grave at Ecclesfield.

Mention should also be made of the books written by her husband Alfred Gatty. He too was quite a prolific author. He encouraged Margaret and often helped her with her writing. He even made occasional contributions to Aunt Judy's Magazine. He edited 'The Life of Dr. Wolff' together with Margaret. He published several books of his sermons. In 1842 he had also worked with Margaret on 'The Life of Dr. Scott', a biography of her father. In 1862 he published a charming little book 'The Bell, Its Origin

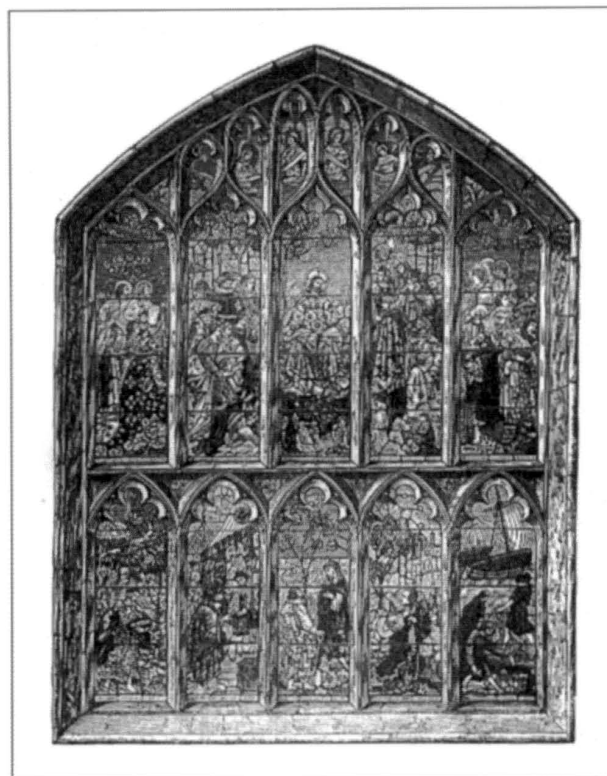

Fig. 7. Memorial to Mrs. Gatty. The Parables Window.

and History' which goes through the many uses of bells, including bell ringing. In 1873, 'Sheffield Past and Present', gives an interesting glimpse of the area in which they lived, with many details of the trades of knife and nail making. He is also known for some books of verse. 'A Life at One Living' (1884) describes the church and parish of Ecclesfield during his time there.

ACKNOWLEDGEMENTS

I would like to thank the many people who have helped with my research, in particular the people of Ecclesfield who still hold the Gattys in their affection. Fig. 4. was kindly supplied by Nicholas Baldwin, Archivist at Great Ormond Street Hospital for Children NHS Trust.

'The Gatty Family, Part 2' describes the 'Book of Sun-Dials' in its various editions.

BIBLIOGRAPHY

- Dictionary of National Biography.
M. Gatty, 'The Book of Sun-Dials'. 4th Edition, London 1900. [H.K.F. Eden and Eleanor Lloyd].
M. Gatty, 'Parables from Nature'. London 1887 edition.
'Margaret Gatty'. Memoir by Juliana Horatia Ewing.
David Young: 'Mrs. Gatty and her Book of Sun-Dials' Bull. BSS 95.3 (1995) October 1995.
Christabel Maxwell: 'Mrs. Gatty & Mrs. Ewing'. London, 1949
Carola Oman: Nelson. London 1947.

THE BSS AWARDS SCHEME

One of the aims of the British Sundial Society is the encouragement of the designing and making of sundials. In pursuit of this objective the Society periodically organises an Awards Scheme for dials newly designed and made. The Awards 2000 Competition, for sundials made during the last five years, culminated at the Society's Annual Conference 31 March-2nd April 2000. On this occasion, when the winners were presented with their awards, Professor Alan Smith, chairman of the Awards Sub-Committee, gave the following address.

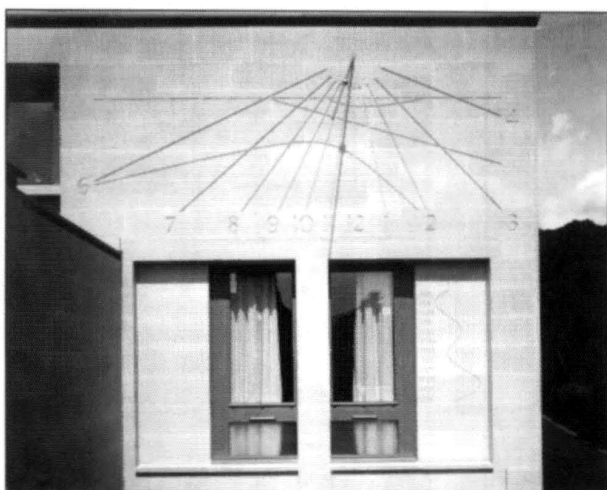

Figures 1-8 are photographs of entries in the BSS Awards Scheme

Fig.1. Vertical Declining dial, Pembroke College, Cambridge: Winner, Professional Class

This is the second occasion on which the British Sundial Society has arranged an Awards Scheme, the first being in 1995. At that time sponsorship came from the Sun Alliance Insurance Company, but now the Society itself has found the necessary funding, as it is in a stronger financial position than it was a few years ago. Last time there were only twelve entrants, submitting a total of eighteen dial designs, and only one major award was made, while four other dials were highly commended. This time, however, there were twenty-two entrants submitting a total of twenty-eight designs; unfortunately six had to be disqualified on the grounds that the dials themselves had not been completed, and we were looking at only a drawing for a dial or at partially finished work. Our awards this year have been far more generous than before, and in fact *eight* awards have been made – a *major award* in the 'Professional' Class, and *three* other commended professional awards; one *major award* in the 'Amateur' Class, along with *two* others commended in that class; and a 'Junior' Award. (Photographs and other details of the

eight award-winning entries were on display at the Annual Conference).



Fig.2. Equatorial Dial, Lodsworth, W. Sussex: Commended, Professional Class

In 1995 we divided the entries into three basic types of dial, 'Horizontal' 'Vertical' and 'Others'. It immediately became apparent that this was unsatisfactory, so this time we decided that it would be better to open the field to *any type of sundial*, be it fixed or portable, or even a simple noon mark. It was also apparent that confusion had formerly arisen between owners, designers, calibrators and makers, and to solve this we resolved on giving awards only to the *designer*, whoever else owned, made or calibrated it, and we also decided that it was necessary to separate the entries into those designed and made by *professional* dial makers, and those who simply produced dials on an amateur basis, - though by 'amateur' we do not imply the word in a derogatory sense, for many 'amateur' dials are clearly of 'professional' quality. To encourage young designers under the age of 21, we established a junior class. We were able to make only one award in this class and we regretted that five students who were designing and making sundials for their



Fig.3. Armillary Sphere, East Horsley, Surrey:
Commended, Professional Class

GCSE Design and Technology examinations had not finished their work and could not be admitted. However, *outside the terms of the Award Scheme* we decided that, in due course, we will give them encouragement by presenting a small prize to one of these students when they have finished their work later this summer.



Fig.5. Noon Lines, Dunscore, Dumfriesshire: Winner,
Amateur Class

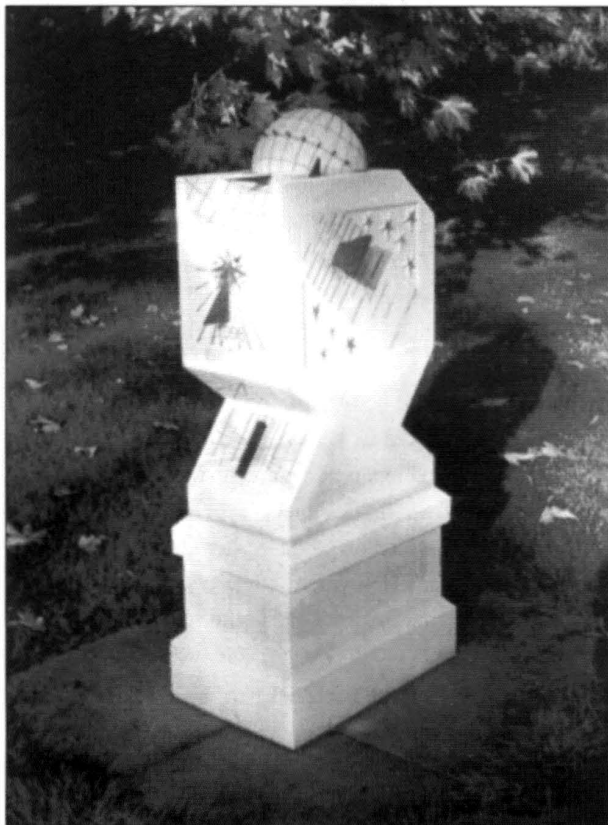

Fig.4. Polyhedral Dial, Christ Church, Oxford:
Commended, Professional Class



Fig.6. Vertical Declining Dial, Bewerley, Harrogate,
Yorks: Commended, Amateur Class

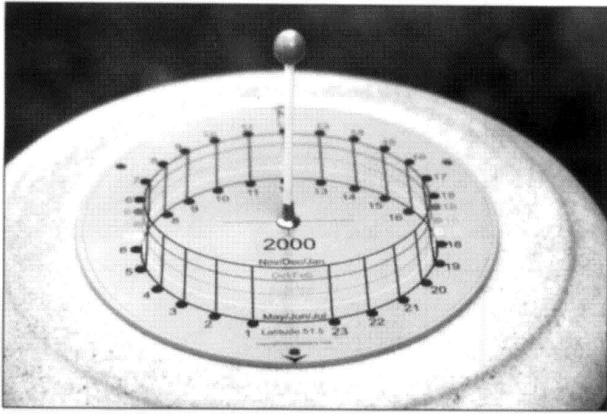

Fig.7. Analemmatic Dial, Badminton, Glos: Commended, Amateur Class

Your Committee had, as you can well imagine, a difficult task in making judgements about an extremely good range of entries. We were looking for quality, - quality of craftsmanship, quality of calibration, quality of setting and suitability to environment, but perhaps most of all quality of imagination. We were not disappointed. The *major award* to **Eric Parry, Architects** for the new dial at Pembroke College, Cambridge, appealed because of its supreme elegance, its clean lines and pure simplicity, its clear functional quality, the exhaustive analysis in its calibration and use of materials, its superb craftsmanship in the making and its highly imaginative use of a good public site on a new building. Likewise the professional design for a garden equatorial dial by **Sally Hersh** (though in a very different setting) exhibited the same approach of clarity and simplicity, combined with fine craftsmanship, and merited an award. The garden armillary dial by **Joanna Migdal**, with its elegant metalwork and declination rings to mark family birthdays, mounted on a rough and contrasting slab of slate in a rose garden, also appealed to our aesthetic judgement. **David Brown's** contemporary version of a Kratzer-type dial in the Pocock Garden at Christ Church, Oxford, was a professional dial superbly carved, which links today with the world of Nicholas Kratzer who was described in 1520 as the "deviser of the King's horologes", and it is a fitting reminder of the former master. In the amateur class our response to **Marilyn Crawford's** sculptural noon mark in Scotland was unanimous. Here was a modern example of the kind of dial which can be seen in the well-known engraving of a noon mark in a French garden, by Nicolas Lancret from the early 18th century. Mrs Crawford's dial exhibits childlike warmth and humour as well as dialling precision in its analemmatic curves. The jolly, wholesome and absolutely appropriate dial for a rough, isolated farmhouse in N Yorkshire by **Donald Bush** was another in the amateur class. It distinguished itself partly by the first rate collaboration between the owner/maker (Dr Philip Rack) and the designer, and partly by its incorporation of locally inspired motifs in its décor.

The imaginative lay-out of a horizontal analemmatic dial by **Noel Stephens** appealed to us because of its somewhat unusual and intriguing graphic presentation, to say nothing of the extremely modest price at which he is able to produce it. Finally we could recommend unreservedly the entry in the junior class by **Elizabeth Partington** for her use of modern materials, fibre-optic technology and sense of exploration and invention in her tablet sundial.

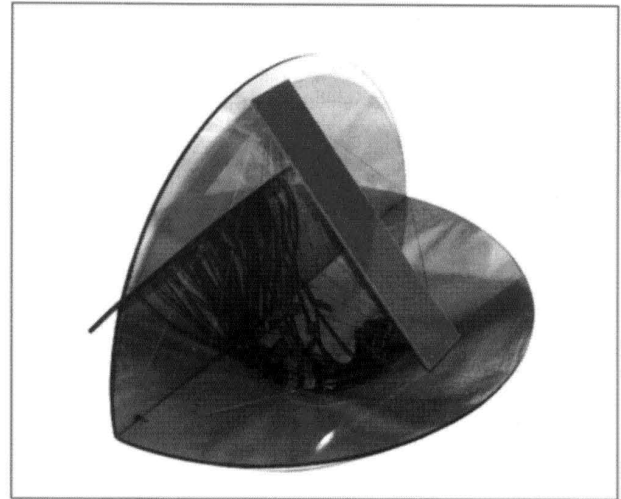

Fig.8. Tablet portable Dial with fibre-optic transmission: Winner, Junior Class

I congratulate all the winners, and thank all those designers who contributed entries to this year's Awards Scheme, including all those who were involved, such as calibrators, sculptors, painters and other craftsmen and women. I feel sure that the results of their work will be a source of inspiration to all who see the entries. Their work overall has been of the highest quality, reflecting the aims, ideals and aspirations of the British Sundial Society. Thanks are also due to the members of my Awards Sub-Committee, Graham Aldred, Doug Bateman, Chris Daniel, Michael Lowne and Nick Nicholls for their hard work and devotion to what has been an interesting and yet demanding task.

Alan Smith, Chairman of the BSS Awards 2000 Sub-Committee

JAMES GREGORY'S MERIDIAN LINE AT ST ANDREWS UNIVERSITY, 1673

JOHN AMSON

James Gregory (1638-1675) was appointed at the age of 30 in 1668 to the new Regius Chair of Mathematics established by Charles II in the University of St Andrews. The University, the first and oldest in Scotland (founded in 1411), was already 250 years old when the firebrand Gregory arrived. His life was full of discoveries but short of years. Gregory was only 36 when he died. He was the first of a Gregory Dynasty, notable mathematicians and medical physicians, that lasted for two hundred years in Scotland and England.

The summer before he went to St Andrews Gregory had been elected a Fellow of the Royal Society (recently founded only four years previously) and had read short papers on gravitation and mechanics. He was a friend of Huygens, had travelled for three years in Europe to consort with his peers, did mathematical research and wrote two books at the University of Padua in 1665, and had attempted the construction of a reflecting telescope (still known as the "Gregorian") nine years before Newton invented his version (the "Newtonian"). He had made many sophisticated mathematical discoveries including a flood of new results in differential calculus for which evidence is extant that he had arrived at these before Newton and Barrow made their own famous discovery of the calculus. In the first fortnight of February 1671 he hit upon one of the most important theorems in all mathematics, known today as the "Taylor Series" - erroneously named after the Cambridge graduate Brook Taylor who re-discovered it 40 years later.

Five years after he had arrived in St Andrews, in 1673, Gregory was commissioned by the University to go to London to purchase *such instruments and utensils as he [...] shall judge most necessary and useful*, and since funds were inadequate for the purpose, he was authorised to make such applications and collections as he saw fit in order that *the fabric and form of the most competent observatory [...] may be builded*.

Gregory went back to his Alma Mater, Aberdeen University, in search of funds, and there *ane collection [was taken] at the Kirk Dores for the Observatorie at Saint Andrews*.

A copy, in the handwriting of the Astronomer Royal, John Flamsteed, was found in Greenwich Observatory some

seventy years ago, of a letter from Gregory, dated 19 July 1673, in which he seeks the advice of Flamsteed concerning instruments for the contemplated observatory at St Andrews. The word *Observatory* is used in this letter in 1673 and in his University Commission, three years earlier than the first recorded quotation in the O.E.D.

Amongst other instruments, Gregory brought back the 70cm Great Astrolabe by Humphrey Cole (with a special plate cut for the Latitude of St Andrews, possibly not by Cole); also a remarkable analemmatic sundial by the prolific London Mathematical Instrument Maker Hilkiah Bedford, and one of the latest, free-pendulum clocks, recently invented by his friend Christian Huygens, and built by the London clockmaker Joseph Knibb - one of the earliest of these superior clocks to be built in Scotland or England. The clock's main dial and large hand counted minutes divided into thirds of twenty seconds each, and the hours were kept on a smaller subsidiary dial. This was possibly the very first "Observatory Regulator Clock", and is still keeping good time on the wall of the University Senate Room 327 years later. A copy of the priceless Cole Astrolabe is on display in the University Physics Building (the original being in secure keeping). And the Hilkiah Sundial is to be exhibited in time for the BSS Scotland 2000 Safari in June.

Gregory established his observatory in what was then the "Long Gallery" or Upper Hall of the Library founded in 1617 by James VI & I. The Library is today known as Parliament Hall because the old Scottish Parliament was sometimes obliged to sit there away from turbulent Edinburgh, before its Adjournment and Union with the English Parliament in 1706, awaiting its re-convening nearly three centuries later as the Devolved Scottish Parliament in Edinburgh last year. The building was completely refurbished in the 1760s. But the Parliament Speaker's Throne and the iron window bracket built by Gregory to support his telescope remain today.

To assist him in his astronomical observations Gregory established a Meridian Line. The actual method he used does not seem to be recorded. Part of the Line was scratched by Gregory into the floor of his Observatory in the Upper Hall, running Northwards from the South-facing window in which he could mount his telescope. The original scratched line was lost when the old Library was

refurbished two centuries ago, but its site is marked by an inlaid wooden strip, 2cm wide, let into the polished wooden floor boards and running for some 8m across the Hall. The polished floor and Line is currently concealed by laid carpets.

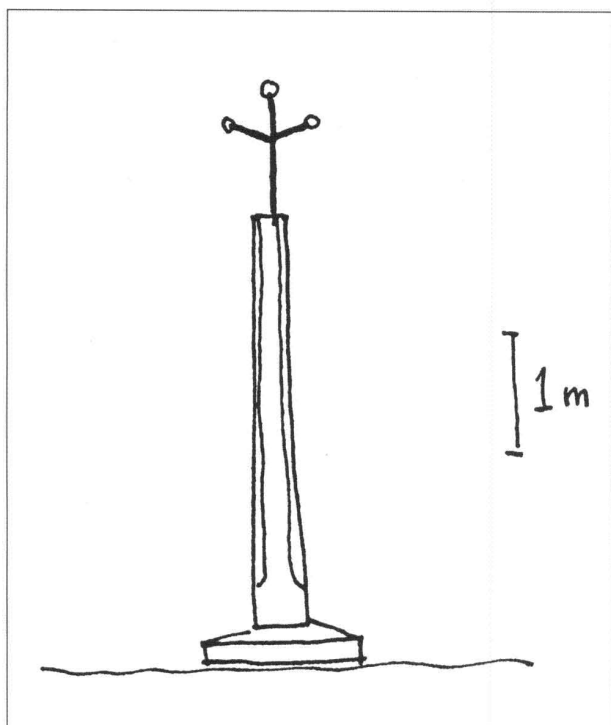

A sketch of Gregory's Pillar

Of perhaps greater scientific interest is Gregory's "virtual Meridian Line". This is still defined as it was in Gregory's time by two original, surviving objects: the iron telescope mount in the Hall window, and his "South Aiming Point" - known to everyone in St Andrews as "Gregory's Pillar".

Gregory's Pillar is located on the skyline of Scoonie Hill, a low hillock rising some 90m above the town to the South. The distance between Gregory's Telescope Bracket and the Pillar is 2391 metres (1.291 miles)

The pillar itself is a single piece of carved stone some 3.5m high. It is 40cm square at the base; its four edges are strongly chamfered beginning about 40cm up from the base and running up to the plain top, giving it an octagonal section. The whole column is tapered, the top being about 30cm across. The original stone base is missing. Mounted centrally in the top of the stone column is a remarkable, well-preserved, iron trident, built of 20mm square-section iron rods and resembling an exotic lightning-conductor. The central vertical rod is about 100cm high; from a point about 25cm down from its tip spring two branches, one to the left and one to the right, each 25cm long and sloping upwards and outwards at 15 degrees to the horizontal. To the tips of the three rods are attached open circular rings

about 7cm in diameter made of thinner metal about 5mm thick, a ring to each tip. The whole trident would have made a superb telescopic Meridian South Aiming Point with a precision possibly unheard of in Europe before Gregory constructed it.

How much use Gregory made of his Meridian Lines is not really known. His enterprise and boundless energy brought the jealous disfavour of his less enterprising university colleagues. He grew disaffected with their prejudiced animosity. In a letter to a friend in Paris he wrote:

"I was ashamed to answer, the affairs of the Observatory of St Andrews were in such a bad condition: the reason of which was, a prejudice the masters of the University did take at the mathematics, because some of their scholars, finding their courses and dictats opposed by what they had studied in the mathematics did mock at their masters and deride them publicly. After this the servants of the colleges got orders not to wait on me at my observations my salary was also kept back from me; and scholars of most eminent rank were violently kept from me, contrary to their own and their parents' wills, the masters persuading them that their brains were not able to endure it."

The year after he had gone to London on his scientific shopping spree he abandoned his observatory and removed himself to a Chair at twice the salary in the more encouraging atmosphere in Edinburgh University, only to go blind and die the following year.

Had the intellectual climate in the St Andrews of the 1670s been more enlightened he may well have stayed and enhanced the reputation of his fledgling observatory. Perhaps his Meridian Line might have gained more widespread recognition, even Royal patronage, and the world might have grown used to using St Andrews Mean Time (SAMT) rather than Greenwich Mean Time (GMT).

The present position of Gregory's Pillar is shown on the large scale (1:25,000) Ordnance Survey Map, St Andrews Sheet, NO 41/51 (Pathfinder Series 363). It is actually labelled "Gregory's Pillar" on the map.

Its OSGB coordinates are

GRID	351000 (east)	714208 (north)
GEOGRAPHIC	N56° 20.36'	W20 47.55'

The coordinates of Gregory's Telescope Bracket in the window in the south-facing wall of Upper Parliament Hall are

OSGB GRID	351015 (east)	716599 (north)
GEOGRAPHIC	N56° 19.07'	W20 47.54'

Using my own "Geogrid" Coordinate Conversion Software, the Geodetic Distance from Bracket to Pillar is calculated to be 2391m as mentioned above, and the Geodetic Bearing from Bracket to Pillar is 179° 42.01'. But for a true Meridian Line this should be 180° 00.00' (true South). If Gregory's Pillar were to be moved westwards by just about 13 metres to give it a lesser grid easting of 350987, then the Bearing would become truly South. This gives some substance to the often-heard gossip that Gregory's Pillar was shifted for convenience by a farmer many years ago. Its present location is in the back garden of a farm cottage. It is still in surprisingly good condition.

ACKNOWLEDGEMENT:

Some of these notes are based on the booklet compiled by H.W Turnbull and G.H.Bushnell, and published in 1939 by

the University of St Andrews for the Celebration of the James Gregory Tercentenary, 1938.

A detailed and informative web-site on Gregory and related topics is at :-

www-history.mcs.st-and.ac.uk/~history/HistTopics/U_of_St_Andrews_History.html

*Author's address:
The Old Manse, 5 Shore,
Anstruther, Fife, KY10 3DY*

CAMBRIDGE SUNDIALS, OLD AND NEW

The Fitzwilliam Museum in Cambridge is running an exhibition until 30th April and a companion series of events entitled "Tempus - The Art of Time" to mark the millennium. The exhibition itself is well worth a visit having a good selection of dials, including a type of Greek hemicyclium.

As part of the series of events, a lecture on "Cambridge Sundials, Old and New" was given by Dr Frank King, an enthusiastic diallist, at the Peterhouse lecture theatre on 13th January. It was an extremely well-attended meeting, most people seeming to know each other; presumably they were local or were connected with the museum or university in some way.

Dr King aimed his talk at a fairly basic level but quite obviously had dialling theory at his fingertips. In a most entertaining manner he was able unhesitatingly and skilfully to explain and to demonstrate to the mainly novice audience the path of the apparent sun around the earth, its altitudes, bearings, declination and the resulting shadows cast by a gnomon throughout the yearly cycle. Whilst most explanations of this employ at least some rudimentary mathematics or drawing, Dr King amusingly used various devices and methods to show direction and length of shadow in a basic practical way which, in the opinion of the writer, was exceedingly clever.

The early concept of the requirement for time measurement was considered and therefore the use of shadow length and direction. The impracticability of a vertical stick or gnomon

to give a meaningful indication throughout the year (analemmatic dials were yet to arrive) was illustrated by the lecturer.

Following from this Dr King demonstrated the need for the gnomon of a sundial to be aligned with the earth's axis; that is, for it to be inclined to the horizontal by an angle equal to the latitude at that place. He proceeded to produce from his table-full of implements and gadgets an umbrella minus its fabric, leaving only the stem and the spokes. With this, using the stem as the gnomon and the spokes as the dial, (I noticed however that his umbrella had only eight spokes and so was not ideal for hour marking) he was able to show in a clear, practical way the design of horizontal and vertical dials. There was surprisingly no discussion of equatorial dials but possibly the delineation of these, being simpler, was assumed.

Slides were then shown of a couple of Cambridge sundials, starting with the famous brainstom of a dial, the colourful masterpiece covering much of the slightly east declining wall of Queens College. Amongst many other attributes this is, of course, a sun and moon dial, the tables under the main dial giving the correction required to obtain an approximate time reading from the moon's shadow. Much of the dial furniture - date curves, sunrise times, azimuths, temporary hour lines etc., was explained, noting obviously the gold painted ball fixed to the gnomon whose shadow was used to determine them.

To illustrate the equation of time Dr King showed slides of the double dial on Magdalene College. These two dials, one for the first half of the year and one for the second, have curved hour lines to correct for the equation of time difference, and so read GMT directly. The dials have a pleasant feature, occasionally seen, that the time is shown by a light spot rather than a shadow.

Dr. King included a few slides showing the somewhat precarious construction process of the large vertical dial he had designed for the south east-declining wall of the Foundress Building of Pembroke College. This dial is

continuously in view of AT&T cameras from a nearby building, and is visible on the internet at www.uk.research.att.com

On completion of the lecture the audience withdrew to an adjacent room where wine was served and further discussion was possible.

*D. Quinn
Rose Cottage, New Green,
Bardfield Saling, Braintree
Essex CM7 5EG,*

READERS' LETTERS

SAXON DIALS AND RUNIC SYMBOLS

David Scott's final instalment on Saxon Dials was interesting, particularly the Orpington dial. The drawing in the Bulletin omits two or three Runic symbols and raises questions over the Roman lettering. The dial is inscribed in Anglo-Saxon, Roman and Runic. This may be unique. The only other dial with runes appears to be the one at Skelton-in-Cleveland (Page, British Museum Publications), a dial which so far does not appear in our records. I would read the first two (Roman) letters as OP rather than OR. The usual word for 'timekeeper' was 'horologium'. I wonder whether one would carve the word 'sundial' on a sundial. The other marks in the R/P sector further confuse the issue, and I would not speculate on any alternative.

The transcription of the Anglo-Saxon seems quite accurate. One rune is a late 'a' and there may be another which curiously has a 'meaning' of 'day'. The third symbol is not very rune-like as it has curved elements. In any case, I imagine that any meaningful interpretation of two or three symbols is impossible. An accurate date may be defined, though, by some expert in the subject.

The 'crossed' radial lines appearing all the way round prevent any alignment being suggested, other than that from the Anglo-Saxon lettering. This would imply that the missing part of the dial is the left segment, and that 'noon' is immediately to the right of the Roman 'O'.

*Tony Wood
5 Leacey Court
Churchdown
Glos., GL3 1LA*

BEDE AND TIMEKEEPING

'The Calendar' by David Ewing Duncan (published by Fourth Estate Ltd) is about Time (but does not explain why January 25th is Burns Night when so much burning goes on on November 5th). However, it is a 'good read' and of interest to those who care about shifting shadows.

The author has much to say about the Venerable Bede's calendrical studies, and mentions the monk's having made a sundial, which he used to determine the dates of the equinoxes. I wonder whether any B.S.S. member has fuller knowledge of this work. Presumably it was described by Bede himself. Perhaps some historian has already come across the record, or at least knows where to find it.

*D.K Ebdon
60, Oxhill Road
Dumbarton
G82 4DG*

THE 'NEW JULIAN' CALENDAR

The year 2000 is a leap year, even in Greece!

First of all: why is it a leap year elsewhere in Europe, since the centennials are not leap years? Yes, but if the centennial date can be divided by 400 with remainder 0, it is again a leap year. Thus, according to the Gregorian Calendar, 2000 is a leap year.

Now, why should it be different in Greece? The Julian Calendar (every 4th year is a leap year without exception) is no longer valid in daily life, but only for the calculation of Easter. So? At the time of the Council of the Orthodox Churches in Constantinople (1923) the Julian Calendar was replaced by the New Julian Calendar¹. This has been in action since 14 October 1923. The progress in ecumenical

agreement has not gone so far as just to take over the Gregorian Calendar introduced in 1582. Why should it have done so? Because the New Julian Calendar is *even more accurate* than the Gregorian Calendar!

Now what is the difference of the two calendars? With the New Julian Calendar the centennials are leap years (ly) *only* if the number of the centennial is divisible by 9 with remainder (rem) 2 or 6.

Year	New Julian	Gregorian
2000	20/9 = 2 rem. 2 ly	20/4 = 5 rem 0 ly
2400	24/9 = 2 rem 6 ly	24/4 = 6 rem 0 ly
2800	28/9 = 3 rem 1 --	28/4 = 7 rem 0 ly

Aha, here comes the small difference. Within the next 800 years we need to find a solution.

Let us consider the accuracy. The 9th Congress of the International Astronomical Union (IAU) has fixed the value of the duration of the tropical year² $T = 365.242199$ d

For calendrical considerations, the rounded value $T = 365.2422$ d is sufficient.

The problem for all calendar designers was, and still is, that T is not an integer number of days. Therefore it is necessary to use intercalation in order to achieve the accuracy in the mean over a long period. The success of this achievement can be calculated by the size of the error, e , as

$$e = (365m + 365n) / (m + n) - T$$

where m = number of common years, n = number of leap years, therefore $m + n$ is the duration of one cycle. The three calendars may now be compared.

Year	m	n	e in d
Julian calendar	3	1	0.0078
Gregorian calendar	303	97	0.0003
New Julian calendar	682	218	0.000022

The error could be made to be zero if one could arrange for 2422 leap years within 10,000 years. What is necessary³ is just to cancel three more days, say in the years 3200, 6400 and 9600 from the Gregorian calendar.

Will it be possible that in future the world can agree on this simple solution?

REFERENCES:

1. Milankovic, M: 'Das Ende des Julianischen Kalenders und der neue Kalender der orientalischen Kirche' *Astronomische Nachrichten*. 220 379-384 (1924)
2. Selsechnikov, S.I.: *Wieviel Monde hat ein Jahr?* Aulis Verlag Deubner, Köln, 1981
3. Zemanek, H: *Kalender und Chronologie* Oldenbourg Verlag, München, Wien, 1990

Dr. Manfred Hüttig
Berliner Str.6
D.38300 Wölfenbüttel,
Germany

BOOK REVIEW

THE SUN IN THE CHURCH: CATHEDRALS AS SOLAR OBSERVATORIES

J. L. Heilbron, Harvard University Press, Cambridge Mass. and London, 1999. Pp366, 8 colour plates, diagrams in text.

ISBN 0-674-85433-0, price £21~95.

This book is concerned with the construction and use of meridian lines in cathedrals and other locations, and includes much ancillary detail necessary for a good understanding of the subject. In this context a meridian line is a horizontal north-south line on the floor of a building, with a small high aperture in one wall, admitting sunlight to form a solar image marking the meridian passage of the sun.

Two matters were of primary concern to the Roman Catholic Church in the sixteenth century. One was the attack on the accepted Earth-centred theory of the solar system by the new sun-centred theory of Copernicus as advocated by Galileo and others. The conflict between dogma and science is present in the background throughout the book. The other matter was the pressing need for reform of the calendar, principally to correct the dates on which Easter Day was observed. Subsequent to the Council of Nicaea in AD 365 Easter Day was adopted as the Sunday following the first full moon after the vernal equinox, but the combined errors in the Julian calendar and the tables of the moon caused Easter to deviate more and more from the proper time. The author gives a lively and comprehensive account of the convoluted history of the attempts at reform which culminated in 1582 with the introduction

of the Gregorian calendar and improved methods of calculating in advance the dates of full moon. This involves tabulated quantities such as the 'golden number', the 'epact' and the 'dominical letter'. Rather curiously there appears to be no clear explanation of the procedure for finding the date of Easter from the tables, but anyone interested has only to consult the method given in the English Book of Common Prayer.

The book continues with descriptions of the spherical geometry of the sky needed to understand the astronomical principles involved, leading into the story of the installation of meridian lines. This is followed in chronological order, with biographical summaries of the designers. Disconcertingly, the story is interrupted by a long study of the rehabilitation of Galileo which, although relevant to the theme, might perhaps have been better placed elsewhere.

Details are given of the painstaking methods by which the lines were laid out. Besides being accurately in the meridian, they needed to be carefully levelled which was usually accomplished with the help of a water trough. To obtain sufficient accuracy the line had to be long¹ with the sunlight aperture high in the building. The line at San Petronio in Bologna (installed in 1653) is nearly 60 metres long with an aperture 27 metres above the floor level: the aperture height at Santa Maria in Florence (1753) is an astonishing 90 metres. The meridian lines were not just simple markings: they were works of art furnished with accurate scales for measuring the position of the solar image and embellished with marble insertions depicting the position of the image at important times and other relevant details. The author discusses the appearance of the sun's image and the many difficulties inherent in making accurate observations.

The most important meridian lines were installed after 1582, and were intended not so much to derive the quantities needed for calendrical reform as to check that the Gregorian reforms had been correct! The primary purposes were to confirm the dates of the equinoxes and the length of the year, but the spirit of scientific enquiry was awakened and other astronomical matters were investigated.

Although consisting of little more than a hole in the wall and a calibrated line on the floor, meridian lines were capable of a remarkable precision. By repeated careful observation and with proper allowance for necessary corrections such as atmospheric refraction, accuracies of a few arc-seconds were attained. The Bologna instrument

receives the most attention, justifiably so as it was one of the very few which produced worthwhile results. Among other achievements it was able to show that the six-monthly difference in the apparent solar diameter from perihelion to aphelion favoured the sun-centred theory of the solar system instead of the Earth-centred Ptolemaic theory. Rather ironic, in view of its location in a cathedral and the implacable opposition of the Church to the Copernican system!

The heyday of meridian lines lasted about 100 years from 1650 to 1750. The author describes the development of the unwieldy long telescopes of the late seventeenth and early eighteenth centuries which, although good for detailed observations, were totally unsuited for positional work. By the middle of the eighteenth century meridian lines were easily surpassed in accuracy by observatory-based meridian instruments with telescopic sights and finely-divided circles. Meridian lines continued to be installed, in secular buildings as well as churches, as noon markers for purposes of regulating clocks. By the 1840's the advent of time distribution by electric telegraph had made them redundant.

It is fortunate that many of these magnificent monuments to a pioneering age are still in existence. An excellent survey has been given by the late Charles Aked¹.

Professor Heilbron has provided an informative and thoroughly researched study. It is perhaps more a book for the enthusiast than the general reader, but the technical sections are not essential for following the overall story of these fascinating instruments.

*C.M.Lowne
24 Ditchling Way
Hailsham, E.Sussex
BN27 3LU*

REFERENCE:

1. C.K. Aked: 'Meridian Lines' *Bull. BSS.* **97.3**, 24-28 (1997)

PHOTOGRAPHING THE TOTAL ECLIPSE OF THE SUN IN BULGARIA, 11TH AUGUST 1999

ROBERT B. SYLVESTER

I decided to photograph the total eclipse as best as I could with portable equipment. It is necessary to secure as large an image as possible of the sun/moon combination and a standard 50mm. lens on a 35mm. single lens reflex camera with an acceptance angle of 45 degrees would give an image of about 0.4mm. diameter. It was therefore essential to use as long a focal length as practicable. The optical set-up I used was an optician's nightmare as regards image quality, as teleconverters not only 'slow' the exposure but degrade the image.

My optical set-up consisted of a Tamron 300mm. f5.6 telephoto lens with a Tamron 2x converter and another 2x converter. This produced a 9mm. diameter sun/moon disk, but at 1200mm. and an effective maximum aperture of ~2, it would necessitate great rigidity in supporting the assembly. The optimum film appeared to be Kodak Gold print film at 100 ISO speed, as that was fine grained enough for detail and had latitude lacking in my usual Kodachrome 25 transparency film.

A house move a week before departing for Bulgaria caused me to mislay a special camera clamp which I had made, so the most portable support I could carry was a pocket tripod which proved totally ineffectual. The camera was essentially operated hand-held.

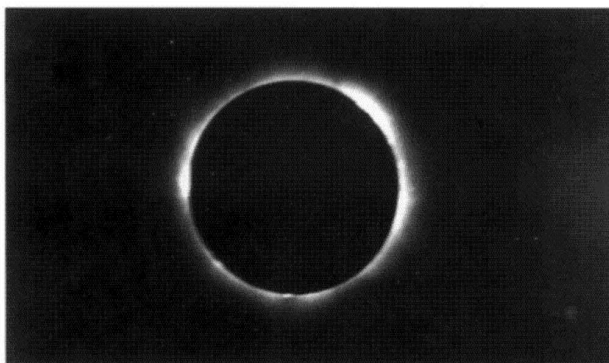

Solar Eclipse in Bulgaria

From the aspect of eyesight safety, it was only practical under the circumstances to photograph during the two minutes of totality. The views I had of corona and prominences were spectacular but the unsteadiness caused the image to whip in and out of the viewfinder. The venture was considered a failure, as after totality, it was noted that I had forgotten to set the camera on its automatic exposure setting and all the pictures were taken at 1/125 second. The 'correct' exposure as afterwards assessed should have been

about 1/15 second and I feared I had greatly underexposed. The film languished in my wife's camera for five and a half months until the film was finished. When eventually processed, to my great surprise, eleven out of the twelve exposures taken during that frantic two minutes produced images. Complete sun/moon disks appeared on five exposures and although several images inevitably had camera shake on them, four produced acceptable photographs. I concluded that it was the latitude of the film that had enabled any images to be printed at all.

The film was mass production processed and the operator did what she could with unusual negatives but the images were printed against a pale grey sky. A locally based printer tried to get better results under my instruction and produced a darker sky and a result nearer to what I saw.

In retrospect, I query my initial assertion that the images were underexposed. The 'correct' exposure I derived was based upon a meter reading and the meter would have striven to expose for unavailable detail on the dark lunar disk. As with a firework or a sunset photograph (ie. a radiant source as opposed to the reflected light images which most photographs are), there is no 'correct' exposure and different exposures will produce different densities of picture, several of which will be acceptable. In the case of my eclipse photographs, if the exposure had been metered, I would have taken the pictures at 1/15 second and ruined every one with camera shake. If a solid support had been used, with 1/15 second exposure, the corona would have extended further but may it have 'burnt out' detail of the prominences.

THE VENTURE WAS WORTHWHILE AND PRODUCED BETTER PHOTOGRAPHS THAN ANTICIPATED

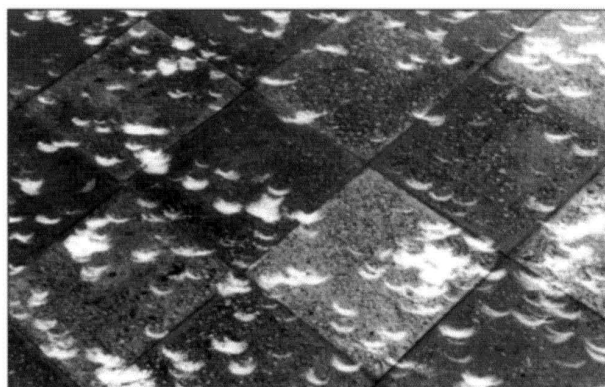

"Sunlight Crescents" on pavement at partial eclipse phase

NOTES FROM THE EDITOR

News from the Far East

We have received the following letter from Sumi Yoichi of the Japan Sundial Society:

'I am pleased to inform you that we have formed the Japan Sundial Society on 25th March 2000. Prof. Gotoh was nominated as the President and Prof. Naosuke Sekiguchi as the Patron. Other activities, and allotting roles, will be arranged by the core members in future.

The United Kingdom is situated in the far west and Japan in the far east. So we feel a strong affinity to your country. Please know that dialling is alive, not only in Japan but also in other Asian countries. I hope that close relations will be created between our two societies'.

Lat. 35°25'N, Long. 36° 36'E e-mail:gnomon@spi.ne.jp

Offprints of Bulletin articles

Contributors of articles for the Bulletin may buy 20 'offprints' of the article after its publication. The cost will vary with the number of pages. The offprints will consist of the pages of the Bulletin, reprinted and stapled along left-hand edges, so the first or last page may carry material other than the article concerned.

Costs for a set of 20 reprints will be as follows: 1 page of A4, £7.20; 2 pages, £8.60; 4 pages, £10.20; 6 pages, £11.80; 8 pages, £13.40

Orders for offprints should be placed with the Editor when the article is submitted. Payment, by cheque, (UK or Eurocheque) to British Sundial Society, should be sent to the Treasurer as soon as the reprints have been received.

THE SEARCH FOR PRE-SAXON SUNDIALS

JOHN WALL

It is generally accepted that the earliest Saxon sundial appears on the south face of the freestanding cross in the churchyard at Bewcastle in Northumberland, which has been dated to the early 8th century.^{1,2} It is improbable that any *Saxon* sundials of earlier date remain to be recorded. That is not to say, however, that there were *no* sundials in Britain prior to the Saxon settlement. The Roman Army under the Emperor Claudius landed in Kent in 42 A.D. Thereafter, for almost 400 years, Britain was *Britannicus*, the northernmost Province of the Roman Empire. Elsewhere in the Empire non-portable sundials were widely employed, associated with public buildings and private houses. The definitive work on Greek and Roman Sundials by Sharon L. Gibbs, first published in 1976³, catalogues 256 known examples, from Belgium in the west to Turkey in the east, from Switzerland in the north to Sudan in the south. There is no reason to suppose that Britannia was an exception to the rule, even though Gibbs fails to include any British examples in her survey. It is highly probable that at least some Roman citizens who made their home here, and some of their travelled Romano-British compatriots, would be versed in the function of sundials, and that they also set them up in appropriate places to record the time of day and the seasons of the year.

My own quest for pre-Saxon sundials in Britain was stimulated by an intriguing reference to one specific Roman

example in an article by Arthur Robert Green, 'Anglo-Saxon Sundials', which appeared in *The Antiquaries Journal* for 1928.⁴ It is briefly described (and we will return to this later) in his Introduction, at the close of which he remarks: 'That the Romans of the British occupation were acquainted with dials is shown by the representation of a horizontal dial on a mosaic pavement at Brading in the Isle of Wight'.⁵ The Roman villa at Brading, beautifully situated in acombe leading down to the sea, was quite a substantial affair. Although the site was occupied from the 1st Century A.D. onwards, in its final form, in the 4th Century, it consisted of a main residential block of 13 rooms and two subsidiary wings arranged round a courtyard. The site was excavated in the 1880's and the remains are now preserved and open to the public.

The main block of the villa is chiefly notable for the remarkable 4th Century figured mosaics in four of its rooms. One large rectangular room contains four panels, each with a border in an intertwined knot pattern. The two largest are square, respectively 12' by 12' and 14' by 14', in which are portrayed mythological scenes. This principal room is divided by two low walls between which there is an oblong panel measuring 10' 6" by 4' 6". (Figure 1). Two lozenges form medallions to the left and right and in the middle there is a square measuring 3' 4" by 3' 4" which immediately arrests our attention. Here there is depicted the

enigmatic figure of an astronomer, a man of science, pointing with his rod to a globe on his left, above which is a pillar surmounted by a *sundial*, and a bowl on his left. It is clear that the scene is symbolic: the astronomer perhaps signifies that by wisdom man can become immortal, in keeping with the immortality theme of other mosaics nearby.



Fig.1 Mosaic representation of a sundial from the Roman Villa at Brading, Isle of Wight.

The owner of this large villa must have been a man of some learning, judging by the obscure symbolism of the mosaics which he commissioned at some time in the 4th Century A.D. The Astronomer Panel indicates that he was familiar with the role of sundials in the Roman world. By itself, however, it cannot be quoted as evidence for the presence of sundials in Roman *Britain*. Because the scene as a whole is symbolic, we cannot expect that the objects within it, including the sundial, will be depicted in a wholly realistic manner. For example the pillar, 2' 8" high, although reminiscent of our garden sundials, is surmounted by its horizontal disc, turned through 90 degrees and upended to appear as if it was a vertical dial. This is clearly a device which the artist employed to represent 'sundial' in general. For this reason, and because the disc is so small (8" in diameter) that the hour-lines have to be crudely drawn, we cannot cite this mosaic picture as evidence for the nature of Roman sundials, in Britain or elsewhere, whether horizontal or vertical. Nevertheless, it remains the earliest representation of a sundial, in any art form, in Britain as a whole.

Before we continue our quest for Roman sundials in Britain, therefore, we are prompted to enquire, what kind of sundial would it most likely be on the evidence of sundials recorded elsewhere in the Roman world? (In this context 'Roman' is synonymous with 'Greek and Roman' since the Greek territories and their 'heritage' were absorbed into the Roman Empire). Gibbs distinguishes four general categories: Spherical, Conical, Planar and Cylindrical. The first two together constitute what we term scaphe dials, from the Greek *scaphe* meaning 'anything that is dug or scooped out'. In gnomonics it refers to the curved bowl shape of these kinds of dials. (Note 1) They were remarkably accurate for their day, having hour-lines, 'day lines' representing the solstices and the equinox, and a

gnomon, such that the sundial was fashioned to function properly at one particular latitude, and no other. The vast majority of Greek and Roman sundials were of this type. By contrast, in Britain today, the majority of our sundials tend to be planar, either horizontal or vertical.

Of the 256 Greek and Roman sundials listed and catalogued by Gibbs only 15 are horizontal. Their furniture is quite dissimilar from the fan of hour-lines radiating from the root of the gnomon with which we are familiar in Britain. The evidence suggests that Greek and Roman diallers preferred conical and spherical dial surfaces. Not one disc-shaped horizontal model is known', (Gibbs).. Again, only 25 sundials are vertical, of which nine are declining (or 'deviating' in Gibbs' terminology). Eleven are south-facing (certainly or probably), and there is insufficient evidence to classify the remaining five. Of the eleven south-facing dials, whether whole or fragmentary, nine are duodecimal - that is, having eleven hour lines which, together with the equinoctial, mark out a twelve hour day. (a) Five of these exhibit a comparatively sophisticated pattern of lines, of the type on the Tower of the Winds in the Agora at Athens (Figure 2, of which more anon). (b) Only three have a simple pattern of lines, as on an example from Ostia Antica, Italy (Figure 3). What is highly significant is that the typical Saxon duodecimal sundial in Britain closely resembles this model. (c) The remaining dial is a variant which is dealt with in more detail below.

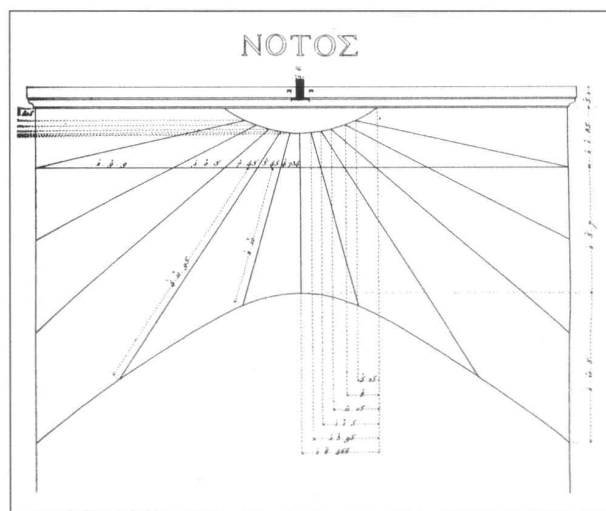

Fig.2 Hour lines and Day lines on the south-facing sundial on the Tower of the Winds in the Agora at Athens.

In Britain we are fortunate to have available for study no less than eleven Roman sundials - nine in the British Museum, one in the Fitzwilliam Museum, Cambridge, and one in Ince Blundell Hall in Lanarkshire.⁶ I hasten to add that not one originated in Britain - all were brought here by collectors and archaeologists from sites abroad. The sites from which most of the 'British group' originated are known, thus establishing the sundial's provenance. As to the

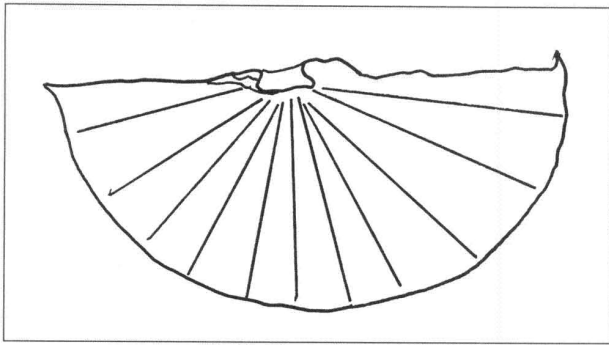

Fig.3 A duodecimal vertical plane sundial from Ostia Antica in Italy. (From Gibbs)

remainder, the latitude of the places for which they were made can be calculated. We can therefore rule out Britain as their place of origin with some confidence. The types of these sundials now preserved in Britain broadly reflect the types identified by Gibbs for the 256 known sundials in the Roman world. Thus five are spherical,⁷ three conical, and three vertical plane, of which two are declining (deviating). The third, now in the British Museum, is interesting because it is a multiple sundial, having four dials on a cube with north, south, east and west faces. The south-facing dial, (c) above, is significant because it is duodecimal and more akin to type (b) 'simple' than type (a) 'sophisticated'.

The sundial marked on the south-facing wall of the famous octagonal Tower of the Winds, designed and built by Andronicus Cyrrestes at some time in the 1st Century B.C. in the Roman Agora in Athens, is clearly very pertinent to this study.⁸ James 'Athenian' Stuart and Nicholas Revette published drawings and measurements of five of the dials in 1762.⁹ They included the south-facing duodecimal dial whose eleven hour lines and three day curves are still preserved in situ to this day (Figure 2).

In the grounds of Shugborough Hall, Staffordshire, there is a replica of the Tower of the Winds. It was commissioned by the 18th century owner of the estate, Thomas Anson, and built by James 'Athenian' Stuart and Charles Cope Trubshaw in 1765. It is not known whether this replica ever had copies of the original sundials on its eight faces; certainly it has none now. However, the existence of this 18th century copy of a classical building keeps alive the hope that other edifices of the Classical Revival period may exist somewhere in the country. If any reader knows of such buildings, I would be interested to have details, for the light which they may be able to shed on their prototypes.

So finally we may begin to evaluate A.R. Green's startling and unequivocal account of the only Roman sundial claimed as indigenous to Britain. It was discovered at Housesteads (*Vercovicium*), now the most impressive and

most visited of the 14 forts strung out along the Roman Wall. Green, (p. 495) writes:

'The dial is unfortunately shown in (Chesters) Museum in a reversed position. It should, of course, have its straight edge, which now rests on the plinth, uppermost, and it is in this, its correct position, that we will examine it. The portion of the dial now remaining consists of part of a style-hole and five, deeply cut, wide lines radiating downwards, the extremities being contained in a circular line. The upper edge of the stone, which may be taken to form another line, is not now visible, being covered by a thick layer of cement, with which it is fixed to the plinth. We may reasonably assume that we have here rather less than half a dial which before it was broken consisted of a half-circle and thirteen lines, and was thus constructed on the duodecimal system to mark the hours from 6. a.m. to 6 p.m. That it is Roman, there seems no reason to doubt: its place of origin points to this, and the method of time-marking is distinctly Roman and was in constant use throughout the Empire. It follows that it is the oldest perpendicular sundial which has so far been found in England'. (Figure 4).

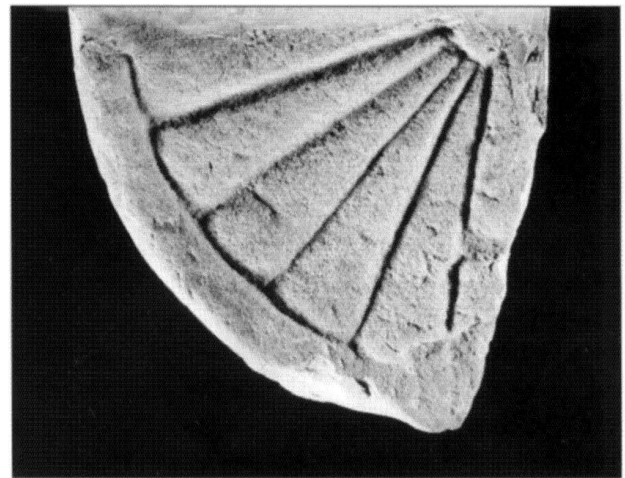

Fig 4 Roman 'sundial' from Housesteads Fort, Hadrian's Wall, on display at Chesters Museum. The photograph (inverted) shows the dial in its 'correct' position.

But is this truly a sundial, and if so, is it Roman? Let us review the evidence. The first scientific excavation at Housesteads was carried out by John Hodgson (1779-1845) in 1822. However, the most thorough archaeological investigation of the site was conducted by Robert Carr Bosanquet (1872 - 1935), Director of the British School at Athens, on behalf of the Society of Antiquaries of Newcastle upon Tyne, in 1898. The results were published in *Archaeologia Aeliana* in 1904¹⁰. Unfortunately, archaeologists at the turn of the century were not quite as scrupulous in recording the exact find-spots of artefacts as

they are today. With that *caveat*, we can be grateful that Bosanquet provides us with line drawings of 'practically all of the carvings in relief discovered during the excavations' - ten items in all, and brief descriptions of eight of them. Six 'are fragments of door or window heads' and two 'are fragments with marginal rope ornament'. That leaves two items undescribed, of which the 'sundial' is one.

Prior to Bosanquet, the defences of the Roman fort and the *vicus* at Housesteads were excavated over a period of many years, beginning in 1838, by John Clayton, FSA (1792-1890), who was Town Clerk of Newcastle and a comparatively wealthy man. He bought as his home a large mansion known as Chesters, after the Roman fort also called Chesters (*Cilurnum*) in the grounds nearby. Clayton owned most of the major sites along a considerable stretch of the Roman Wall, having bought them to save them from destruction. Objects from these sites, known as the Clayton Collection, were housed in a Museum provided for them at Chesters. A definitive Catalogue of the finds, together with others added from Bosanquet's excavations, was published in 1903.¹¹ The 'sundial' is entered in the Catalogue, with a description, as item no. 13: 'Portion of a stone semicircular, vertical sun-dial, thus described in Gatty, *The Book of Sundials*, London, 1900, p.43:- "It is quadrant in shape, 10 in. deep and 2 in. thick. There are five distinct rays cut in the surface, springing from a hole in the upper edge, which no doubt held a gnomon; these rays end in a border line that runs along the curved side of the stone, an inch from the margin. One side of the fragment is jagged, as if the semicircle had been broken across the middle; if complete it would have been divided into eleven spaces." (No.273.) From Borcovicus (*sic*). The sundial is also reproduced, from a photograph, in that part of the Catalogue which deals with Clayton's excavations at the major sites. (Budge)

The stone is still on display in the Museum at Chesters (a later building provided by the National Trust, but now administered by English Heritage). It is clear that Bosanquet did not recognise it as a sundial, because he included it without comment, in the Report of his excavations, in the figure drawings of 'Ten Architectural Details'. (The presence of a hole at the apex of the pattern carved on the stone, which is normally occupied by a gnomon in this type of sundial, appears to be conclusive. The pattern therefore cannot be simply a fan motif which belonged to a decorative embellishment to a door or window surround).

It is also clear that when the first Museum was established (prior to the publication of the Catalogue), the authorities also did not recognise it as a sundial (or else they were

ignorant of basic gnomonics), since it was displayed upside down - as it remains to this day. When F.G Simpson excavated various structures in the fort in 1910-11, some of the finds were added to the Collection. His wife Grace possessed a copy of the Catalogue annotated in her own hand. Against the photographic reproduction of the sundial she has written 'Upside Down!'. Grace Simpson was probably the first, as she was certainly not the last, to recognise the error.

Mrs Gatty's observation 'if complete, it would have been divided into eleven spaces' calls for comment. Five hour-lines are visible on the surviving portion of the sundial. With slight variations the angle subtended by each pair is 15°. By extrapolation, the complete semicircle would have accommodated eleven lines which, together with the equinoctial, would mark out twelve spaces - the Roman duodecimal norm. (Note 2). Unfortunately, the cement rendering which was used to stabilise the sundial so that it could be mounted 'upside down' on its plinth, has had the effect of infilling and obscuring the equinoctial line and most of the hole for the gnomon. It has also obscured the stubs of six hour-lines (although the line of one of them can still be traced), the remainder of which would have been continued on the missing portion of the sundial.

I conclude that this stone is indeed part of a Roman sundial set up at Housesteads during the Roman occupation. Evidently Sharon Gibbs was quite unaware of its existence when she came to compile her Catalogue of Greek and Roman Sundials. There remains the remote possibility that it was set up at Housesteads during the early Saxon period, and erroneously included by Bosanquet in his group of verifiable Roman finds. If that were the case, we would have expected other Saxon sculptured stones to come to light at Housesteads, which is itself improbable given the known Saxon aversion to settlement in the ruins of those Roman sites which remained in Britain in the Saxon period.

We can only speculate as to the purpose of this sundial, found as it was in association with a fort in the Military Zone. In contrast to spherical sundials, which were the norm in the Roman World, it cannot have told the time of day or the seasons of the year with any degree of accuracy. Indeed the contrast is between a relatively sophisticated dial marking equal hours throughout the year, and a relatively simple dial marking unequal hours which varied with the seasons. Its purpose may well have been symbolic - for example of the passage of time in this remote outpost. But it is unlikely that we will ever know with certainty.

There has been much debate concerning the origins of the typical Saxon sundial - from what prototypes was it derived, and what were the stages of its transmission to

Britain? David Scott writes: 'Sundials in Anglo-Saxon England were derived ultimately from the Graeco--Roman hemicycle (corresponding to Gibbs' Hemisphere group of Scaphe dials). The early Christians in Italy, perhaps acting on Pope Sabinian's edict about placing sundials on the walls of churches, may have taken the pattern of lines as seen from the front of a hemicycle (i.e. a projection), and transferred it to a plane surface, giving the familiar protractor-like semicircle'. (Scott). He adds the intriguing suggestion that the Ostia Antica sundial mentioned above may have been the kind illustrated in the books brought to England by Benedict Biscop for his monastery at Monkwearmouth in Durham towards the end of the 7th Century. However, if we are right in characterising the Housesteads stone as a Roman planar vertical sundial, and if we suppose that there were others of its kind set up on Roman buildings elsewhere in Britain which have not yet come to light, then there may well have been sources for Anglo-Saxon sundials much nearer home. The Housesteads example is strikingly similar to the 'simple' duodecimal type exemplified by the sundial from Ostia Antica.

As far as we know, Greek and Roman sundials did not serve an overtly religious purpose. In contrast, Anglo-Saxon sundials can be assumed to have had a religious function, from the fact that, almost invariably, they have been found fixed to the walls of churches, except where they have been relocated. In addition, in some cases, certain hour-lines are marked with the cross. It is probable that the duodecimal system was copied because it was well adapted to the Saxon Church's observance of the Divine Office (*Officium Divinum*), or Canonical Hours. The arrangement of the eight daily Offices (the 'Night Office' and the seven 'Day Hours') was fixed in detail in the Rule of St Benedict of Nursia (c.480-c.550), who took as his basis the Roman use. This same use was first introduced in England in the 7th Century. The duodecimal system was also amenable to a corresponding octaval division of the day/night having three-hour divisions which some have called 'tides'. It is these which are sometimes found marked with a cross, as at Bewcastle.(Note 3)

The proposition that duodecimal Saxon sundials derived from an indigenous Roman model depends upon the survival of such a model through a 'Dark Age' of some 200 years, from the departure of the Romans from these shores, c. 410 A. D., to the foundation of Saxon stone churches in the early 7th Century, following the Mission of St. Augustine to Kent in 600 A.D. That is not impossible, given the survival of so many Saxon sundials themselves over a much longer period of time to the present day. Fortunate will be the archaeologist who unearths a second, complete sundial of Roman provenance in England, to clinch the argument!

ACKNOWLEDGEMENTS:

The author acknowledges much helpful information and advice from Georgina Plowright, Curator of the Chesters Museum. The photograph, Figure 4, is reproduced courtesy of English Heritage.

NOTES:

Note 1: 'If you put your nose pointing to the sun and open your mouth wide, you will show all passers-by the time of day'. *Anthologia Graeca*, 11,418, quoted by Gibbs.

Note 2: Even upside down the sundial is not mounted in an exactly horizontal position. The 'equatorial line', were it visible, would be tilted anticlockwise by some 3°.

Note 3: The duodecimal system cannot readily accommodate the 'half-tide' periods of one-and-a-half hours; see Wall, pp94-96, Figs 1-6.

REFERENCES:

1. Wall, John: *Yorkshire Archaeological Journal* 69 93-117,(1997).
2. Haigh, D.H.: 'The Saxon Cross at Bewcastle' *Archaeologia Aeliana, (new series)*1, 149-193 (1857)
3. Gibbs, S.L: *Greek and Roman Sundials* Yale University Press, New Haven & London, 1976.
4. Green, A.R: 'Anglo-Saxon Sundials' *The Antiquaries Journal* 8, 489-516 (1928).
5. Page, E.W.(ed) *Victoria County History: Hampshire* 1, 314-316 (1900).
6. Lippincott,K: *The Story of Time* Merrell Holberton, London, (1999).
7. Scott, D: 'Sundials in Anglo-Saxon England' *Bull.BSS* 10, 122-128, (1999).See also Lippincott, p.108.
8. Hüttig, M.: 'Analysis of the Sundials on the Tower of the Winds, Athens' *Bull.BSS* 10, 12-15 (1998).
9. Stuart, J & Revett, N: *Antiquities of Athens, Vol. 1, 2nd Ed.* 46-47, and Plates XII,XIX,XX. (1825).
10. Bosanquet, R.C: 'The Roman Camp at Housesteads (Brocovicus): Report of excavations in 1898' *Archaeologia Aeliana, (new series)* 25, 193-300 (1904)
11. Budge, E.A.W: *An Account of the Roman Antiquities Preserved in the Museum at Chesters, Northumberland.* London, 1903.

Author's address:
 Drystones
 7 Waydale Close
 Kirkbymoorside
 York, YO6

DIAL DEALINGS

MIKE COWHAM



The past few months have seen few sales of importance. However, the sale at Christies on 13 April contained some exceptionally good dials.

The interior of an astronomical compendium, thought to be Italian, is shown in Fig.1. Its lid carries a nocturnal and lunar conversion scales. The interior has a rather delicate equinoctial sundial, of form similar to the BSS logo, placed over a magnetic compass. Can you believe that all this will fold down flat to go neatly into the box? I tried it, and eventually got it to fold away. It seems so fragile. It is amazing that it has survived the last 300+ years. This compendium is another of the wonderful objects that was exhibited in Brussels in 'La Mesure du Temp dans les Collections Belges' in 1984. The catalogue then described it as German. (The catalogue for this exhibition is still available from specialist book dealers. It is a must for all interested in portable dials, clocks and watches.) This compendium estimated £26,000 – 30,000 failed to sell.



Fig. 1. Gilt Brass Astronomical Compendium.

A good quality ivory diptych dial made by a member of the Tucher family (probably Thomas) in Nuremberg is illustrated in Fig. 2. Note the spellings of the town names punched inside the upper leaf. The unusual ones are Malant, Prawant, Elsa, Paeirn, Sweten and Liflant. The spelling of town names did vary dramatically at the time that this dial was made, but none of these places are immediately recognisable. It sold for £9,400.

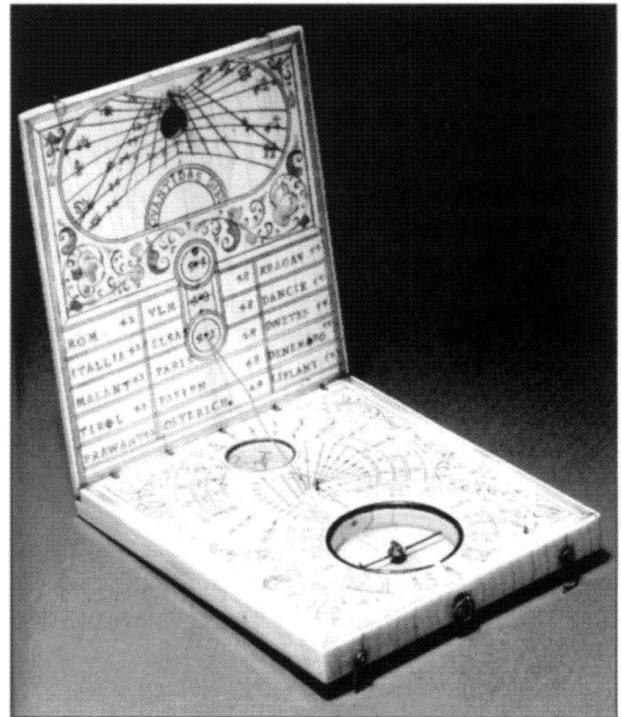

Fig. 2. Ivory Diptych Dial by Tucher.

Fig.3. shows another ivory diptych dial from Nuremberg, this time by Joseph Ducher, and is dated 1642. It is charmingly engraved with a small picture of a village. Sometimes such scenes depict actual villages or towns and can be an important historical record of the place. Notice the scaphe dial in the lower leaf. This is engraved with Italian Hours, (24 hours long starting at sunset). Unusually it does not have the scales for Babylonian hours. Note how the latitude is marked in the scaphe in the form p45d. Estimated £8,000 – 10,000, this too failed to sell.

One item of considerable interest was an English, late 17th-Century simple ring (or poke) dial that was found on the shore of James Island in the Galapagos. In spite of it having been washed by the sea for many years its condition was quite good, although the sliding cursor was immovable. Its only real damage was some rounding of the outer edges.

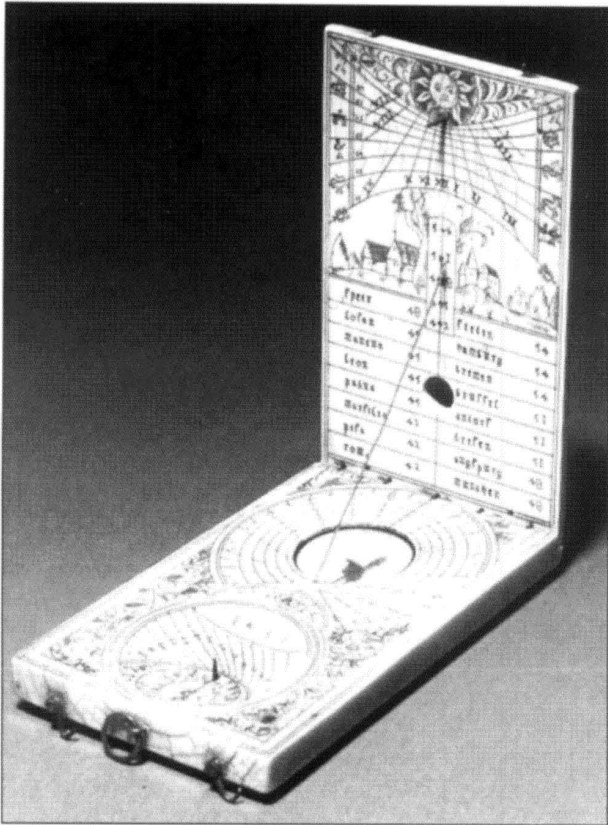

Fig. 3. Nuremberg Ivory Diptych Dial by Joseph Ducher, 1642.

On the outside of the ring an unusual decorative patterning is still visible. This dial must have been lost in the early 18th-Century. This was at a time when very few British ships ventured to the Galapagos. We can therefore speculate that it may come from the wreck of a buccaneer. If only these objects could talk! It sold for £940.

Fig.4. shows a late 16th-Century French gilt brass nocturnal. It is unsigned, but dated 1588. On the side shown is a sundial with its folding gnomon. In the centre is a volvelle with an aperture to show the moon's phase so that it could be used for telling the time from the moon. In practice, a readable shadow from moonlight on a gilt surface would be impossible to discern, even near to full moon, so it is unlikely to have been a 'serious' instrument. The nocturnal made £11,750.

Fig.5 shows a nice octagonal ivory diptych dial from Charles Bloud Le Jeune Dieppe. As with most dials of its type, it is four dials in one. On its lid are two dials, an equatorial dial and a polar dial, both operated from a (now missing) pin gnomon, and adjustable to any latitude. Inside is the usual string gnomon dial for a fixed latitude (string missing) and the Bloud favourite, magnetic azimuth dial. To use this, the dial body is turned so that the shadow of the lid falls exactly along the line of the base. The time is then read from the position of the compass needle at the point

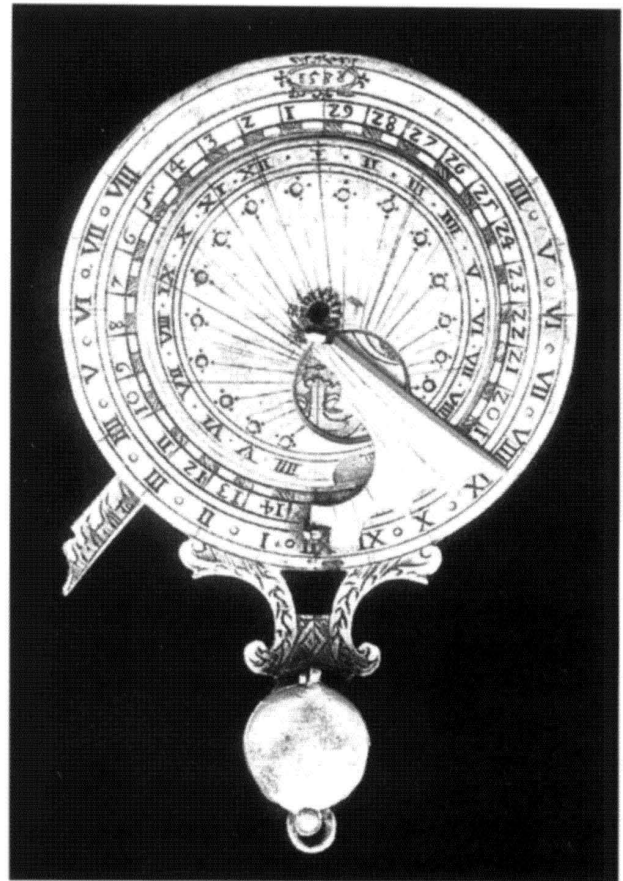

Fig. 4. French gilt brass nocturnal, 1588.

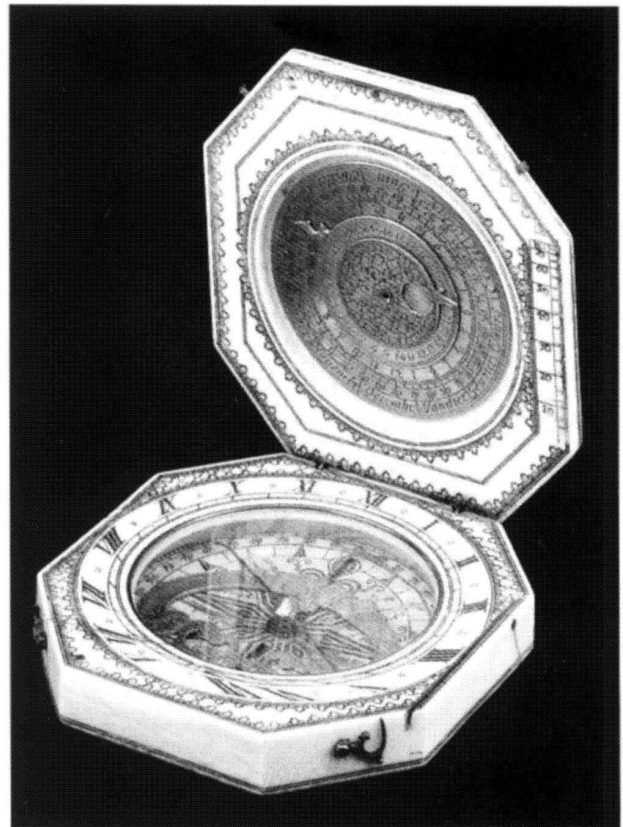

Fig. 5. Magnetic Azimuth Dial by Charles Bloud Le Jeune, Dieppe.

where it crosses the elliptical hour scale beneath it. This scale moves north / south to adjust for the different seasons, being linked by a cam mechanism to the calendar scale on its under face. It sold for £3055.

An Augsburg dial by Lorenz Grassl, (Fig. 6.), made unusually in silver, was another unusual piece. I noticed four deep scratch marks on the edge of the chapter ring hinge. Further investigation showed these marks to be on virtually every part. The maker put them there so that parts of this dial would not get mixed with those of similar dials in the same batch. We can therefore tell that this dial was part of a batch of at least four similar sundials. This is good evidence that dials of this period, c1780, were no longer individual commissions, and were early forms of mass production. Sold for £2585.

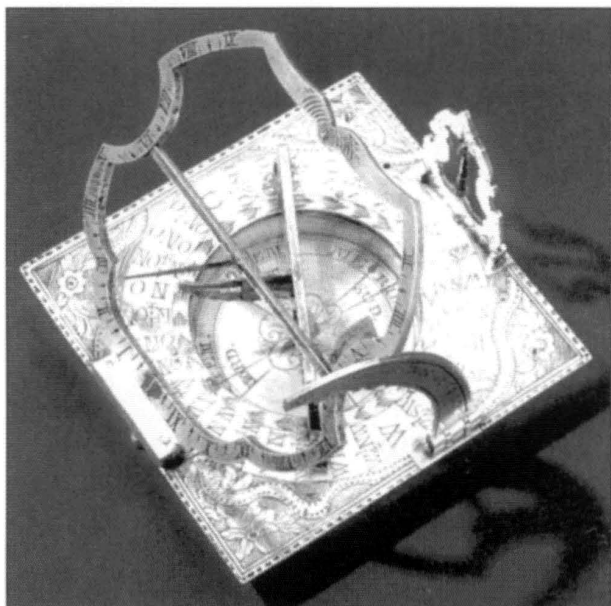

Fig. 6. Silver Augsburg Dial by Lorenz Grassl.

The Scientific Instrument Fair on Sunday 16 April was as usual quite lively, with prospective customers' queuing outside at opening time. Bertrand Thiébaud from Paris, had several interesting portable dials with him. I was on the lookout for unusual dials or rare makers. The one that took my attention was a fairly standard silver Butterfield dial, but this one had a large bracket holding a plumb bob, suspended by a thread. The bracket was the height of the dimension across the dial. Surely such accuracy in a Butterfield dial was not warranted?

FORTHCOMING SALES FOR 2000

As these dates can change, check before travelling to view.

Christie's South Kensington. Jeremy Collins – 020 7321 3149
1 June
(17 October. Los Angeles).
7 December.

Sotheby's Catherine Sothom –
020 7293 5209
24 May
21 September
19 December?
www.sothebys.amazon.com

Philips James Stratton –
020 7629 6602
18 July
7 November

Bonhams Alexander Crum-Ewing –
020 7393 3950
29 June
1 November

Scientific Instrument Fair Peter Delehar –
Portman Hotel, London. 0181 866 8659
29 October

ACKNOWLEDGEMENTS

I would like to thank Christie's South Kensington for their kind permission to use their photographs. The photographs remain their copyright.

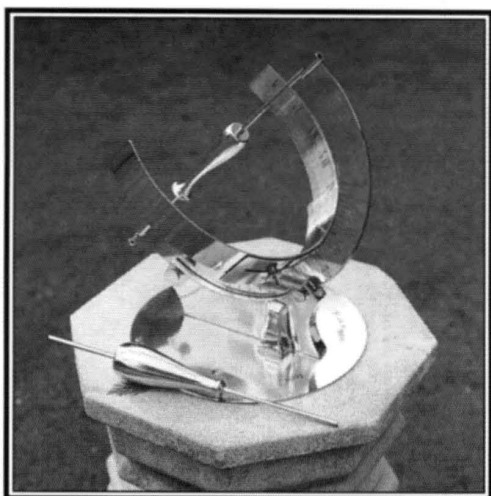

A colour brochure showing a range of dials and armillaries in brass or bronze available from:

CONNOISSEUR SUN DIALS

Lane's End, Strefford, Craven Arms,
Shropshire. SY7 8DE

Tel / Fax: +44 (0)1588 672126

email: sundials@ouvip.com

Website: <http://www.sundials.co.uk/connois>

PHOTOGRAPHING MASS DIALS

TONY WOOD

The new Mass Dial Register will contain a photograph, where possible, of each dial recorded. Naturally the best available will be chosen; this means that recorders (or, indeed, any member) should not hesitate to send in a recent photograph.

The rise of the fully automated camera and the use of fast films means that good pictures can now be produced by 'point and shoot' and they may well be better than 10 or 15 year old ones.

There is an inevitable clash between reality: - a late afternoon in wet February with an Instamatic in your rambler's rucksack; and the counsel of perfection: - 'make sure the sun is shining'.

Firstly, the dials themselves possess some attributes in our favour: usually they are flat, they are about chest high, they don't move and they are in quiet places.

Secondly, on the down side, they may be faint in a dark corner.

As for the camera and associated equipment I feel it is best to say very little. Provided you have a camera that can focus down to a metre the rest is dependent on what you are prepared to carry whilst out a-dialling. One item I would not go without is, surprisingly, a long focus lens (interchangeable or zoom) as I will explain.

Combining the above comments we see that since the dial is flat, 'depth of field' is no problem, so a big aperture and a high shutter speed (1/500th and faster) can be used as a matter of course. This tackles the problem of camera shake, the cause of so many unsharp pictures. And get in as close as you can: the bigger the better in terms of frame filling.

Even the above simple advice requires the odd caveat. A horizontal format photograph is to be preferred, the reason being that it is sometimes difficult to tell which way is 'up' when you get the prints back two months later. The paper maker's name on the back will tell you but vertical format shots depend on how you grip the camera that day. I realise of course that we do not all have control over aperture and

shutter speed in these days of fully automated cameras but they do seem to cope very well on the whole. Counsel of perfection is to stick a white spot 'top right' before taking your shot. When you write details on the back of your print put 'TOP' at the top!

The long lens? If the dial is above head height, then stepping back and using a long lens reduces the distortion for our angle-measuring enthusiasts. It is easier to measure at home from the photo than in a wet and windy graveyard.

In addition to a close-up 'fill the frame' picture some of us take a 'location shot' and this is a useful back-up if you forget which dial was photographed where. Keeping a record of the photos is, of course, vital. I recently attributed two dials to the wrong church because the notes were poorly laid out in my notebook.

Dials in dark places

Before we actually go into dark places it can be noted that the noon day sun is a mixed blessing and can produce pictures with poor detail. Try a shot with shade over and adjust exposure accordingly. Morning and afternoon give better shadows but we don't always have choice of time or sun. Dull days can produce good pictures providing your exposure is correct; don't miss a photo because it isn't sunny.

Dark corners usually mean the porch. At least there's somewhere to put your shoulder against when the exposure required goes up to a second or two or three. The usual advice is to avoid flash (certainly avoid flash outside the church). In a porch (or inside the church) give it a try but take a shot without flash as well if you can. Also: open the porch doors, switch on the per No. and name plus anything else you care to add. All the foregoing assumes we are talking about colour prints of standard size or 'king-size'. Those who are in the transparency age or the electronic age will no doubt send their appendices to our Editor.

Keep snapping and sending.

Fig.1 & Fig.2:

St. Barbara's Church, Ashtop-under-Hill, Worcestershire. Mass Dial photographed with colour film 200ASA, shutter speed 1/1000 with automatic aperture selection; Subject distances: (fig.1) 300mm, (fig.2) 400mm. Poor picture was in spite of good sunshine and exposure. Counsel of perfection is to move the sun round to east or west. Noon sun has similar effect to flash.

Fig.3 & Fig.4:

All Saint's Church, Lydiard Millicent, Wilts.

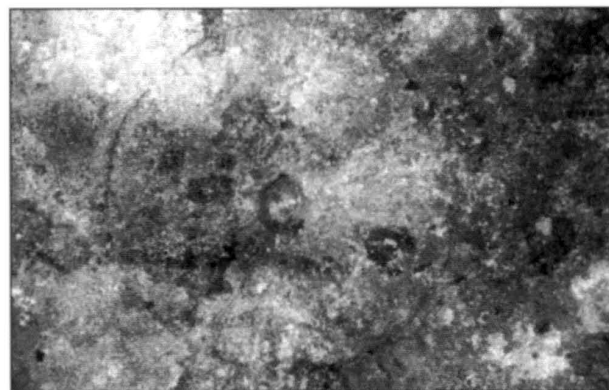

Fig.1 Unlucky Light

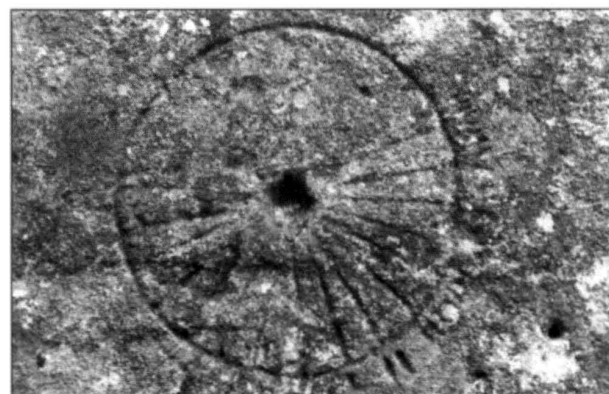

Fig.2 Lucky Light



Fig.3 Unlucky Light



Fig.4 Lucky Light

*Author's address:
5 Leacey Court,
Churchdown,
Gloucester,
GL3 1LA.*

AN EDUCATIONAL HELIOCHRONOMETER

ANDRÉE CHOTKIEWICZ

The Pilkington-Gibbs heliochronometer has featured several times in our journal, notably in BSS Bull.97.2 (1997). The dial-plate has a smaller plate upon the main plate, so that the instrument can be set for the calendar date each day. An internal mechanism compensates the dial reading for the equation of time. A few of these instruments are available second-hand today but they are expensive.

Alternatively, the heliochronometer described by R.N. and M.W. Mayall in their book 'Sundials' is well worth making, especially by those interested in the educational aspects of sundial construction and use. It measures visibly the changing declination of the sun throughout the year and the sun's gains and losses over GMT which are referred to as the equation of time. I made a model using wood, and throughout the summer it gave readings within an accuracy of five minutes. A school or College craft shop could easily make one from metal or plastic which would not be susceptible to humidity changes.

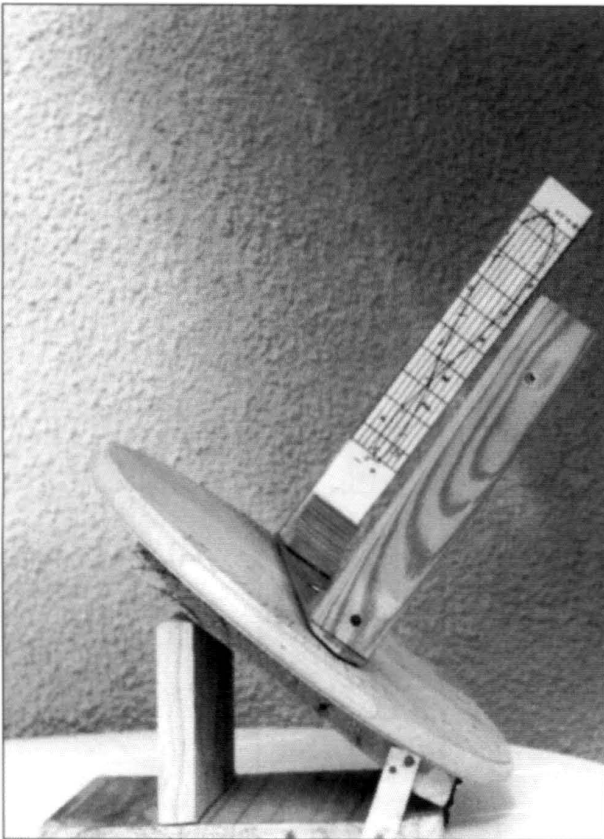

Fig.1 Photograph of the completed model

The photograph (Fig.1) illustrates the general structure of the model, and Diagram 1 of Fig.2 accentuates some important points in its design. In particular, the height of the upright arms must allow for the change in declination from

$-23\frac{1}{2}^{\circ}$ to $+23\frac{1}{2}^{\circ}$, and the arms must be at 90° to the alidade. The gnomon aperture must be mounted at exactly the same height as the zero declination on the scale; and the scale itself must be drawn specifically relative to the internal distance between the two arms. A suitable distance, referred to as x in Fig.2 Diagram 2, is 20 cm.

In drawing the scale, refer to Diagram 2. First the midpoint of the scale is drawn. This midpoint, O, is marked, and the zero declination line is drawn through this point at right-angles to the midline. The zero declination line is extended x cm from O to A, and a line is drawn through A, to represent the style position with A as the gnomon. The style is set at 90° to the zero line. Then the solstice positions are marked by subtending the $23\frac{1}{2}^{\circ}$ angles as shown. The 5° , 10° , 15° and 20° are also subtended onto the midline to mark the position of the declination lines, as shown in Diagram 3. Extend from O to B, x cm.

Date	Dec ^o	E _{min}	Date	Dec ^o	E _{min}
Jan 1	-23	+3.2	July 1	+23	+3.5
10	-22	+7.2	10	+22	+5.1
20	-20	+11	20	+21	+6.2
31	-17½	+13.4	31	+18½	+6.3
Feb 1	-17	+13.4	Aug 1	+18	+6.2
10	-14½	+14.3	10	+16	+5.4
20	-11	+13.9	20	+12½	+3.5
28	-8	+12.6	31	+9	+0.5
Mar 1	-7½	+12.5	Sep 1	+8½	0.2
10	-4	+10.5	10	5	-2.8
21	0	+7.7	21	0	-6.7
31	+4	+4.5	30	-2½	-9.8
Apr 1	+4½	+4.1	Oct 1	-3	-10.1
10	+8	+1.5	10	-6½	-12.7
16	+10	0	20	-10	-15
20	+14½	-2.7	31	-14	-16.3
May 1	+15	-2.9	Nov 1	-14½	-16.3
10	+17½	-3.7	10	-17	-16.1
20	+20	-3.6	20	-19½	-14.5
31	+22	-2.5	30	-21½	-11.5
June 1	+22	-2.4	Dec 1	-22	-11.2
14	+23½	0	6	-22½	-9.2
21	+23½	+1.5	25	-23½	+0.2
30	+23	+3.4	31	-23	2.7

Table of data for equation of time. There can be minor variations

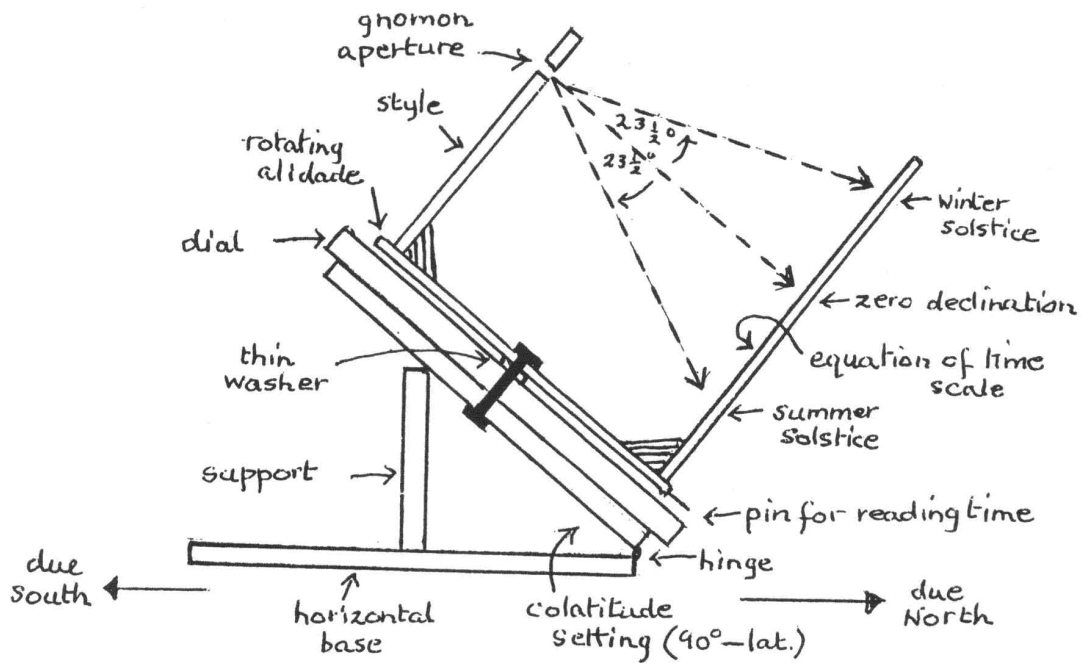
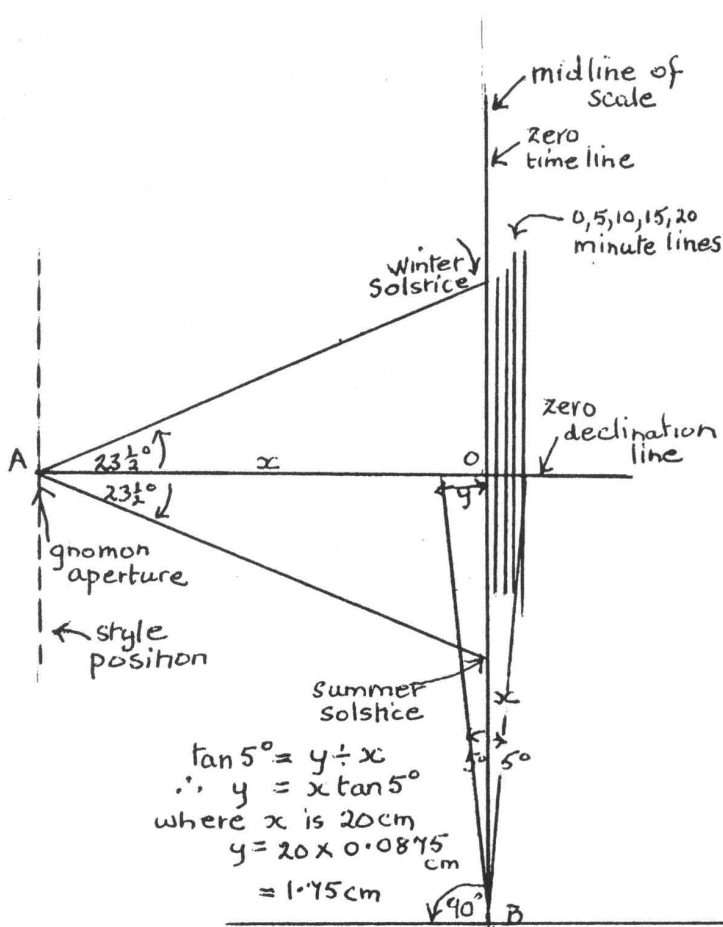

Diagram 1



(not to scale) Diagram 2 (method only)

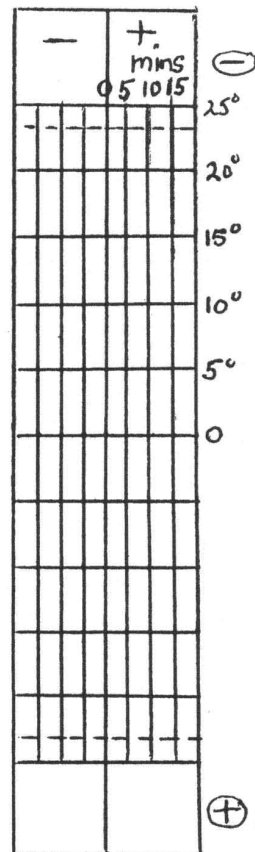

Diagram 3

Fig.2 Construction diagrams: Diagram 1, General structure of the heliochronometer; Diagram 2, Laying out the scale for the Equation of Time; Diagram 3, General layout of the equation of time scale

Rather than attempting to subtend the small angles needed to delineate the time lines (1° is equivalent to 4 mins.) it is better to determine the distance y mathematically. Where x is 20cm, y is 1.75cm. With care, this distance can be measured both sides of the midline, and then divided by eye into four equal amounts to give the positions of the 5,10,15 and 20 minute time lines (drawn vertically). It is now possible to complete the time scale as shown in Diagram 3, and the equation of time can be plotted on it. I have gathered the data to be plotted in table form. The beginning and end of each month should be marked on the graph.

In my own dial I have drawn 12 o'clock in the due north position. To read the dial the light spot is focussed onto the equation of time line on the correct date position, and gives GMT, if you add or subtract four minutes for every degree you are, west or east of Greenwich.

Or you can set your dial the required number of degrees east or west of north to give GMT directly. The angle of the dial plate equals the co-latitude.

*Author's address:
Lithuanica, Helston Village,
Helston, Cornwall, TR12 6JY*

A PORTABLE ANALEMMATIC DIAL

JOHN SINGLETON

The circular version of the analemmatic dial is attributed by Sawyer¹ to Samuel Foster, It features hour marks uniformly spaced around a circle, and (for a horizontal dial) a gnomon inclined at angle $E = \theta/2 + 45$ degrees ($\theta =$ latitude). The required position for the gnomon varies, along a north-south track, depending on the sun's declination and therefore on the time of year.

For a given track-length (t), the diameter (d) of the circle is given by $d/t = \cot 23\frac{1}{2} \tan E = 2.3 \tan E$. So, for a portable dial, we may draw a family of concentric circles to cover latitudes from say 50 to 60 degrees North (see Fig.1 page 104). Due to the linear hours scale, adjustments for longitude and equation of time can be made by rotation. Thus in Fig.1 we have a fixed centre disc carrying the gnomon. Around this is a ring for longitude adjustment (which could carry alternative marks to display BST). This ring also carries a linear date scale. A final outer ring carries a non-linear date scale; this is aligned with the linear one at the current date to provide EOT correction, after Scott². The outer ring also carries the radii representing the hours. The time is indicated by the point where the gnomon's shadow cuts the circle of relevant latitude.

The gnomon rod must be adjustable in elevation (E), and in its distance from the centre of the circles. This is given by $\frac{1}{2}t \tan D$ ($D =$ sun's declination), and is taken care of by setting the root of the gnomon against the date scale along the track. The gnomon length should be at least 1.13 times the radius of the circle for latitude 60°.

REFERENCES

1. F.W. Sawyer: 'Samuel Foster of Gresham College' *Bull BSS*. **97.1**, 2-15 (1997)
2. A.C. Scott: 'A Design for a Horizontal Sundial Adjustable by Rotation around a Polar Axis' *Bull.BSS*. **11**, 115-117 (1999)

*Author's address:
Old Coach House,
Salcombe Road, Newbury,
Berks. RG14 6ED*

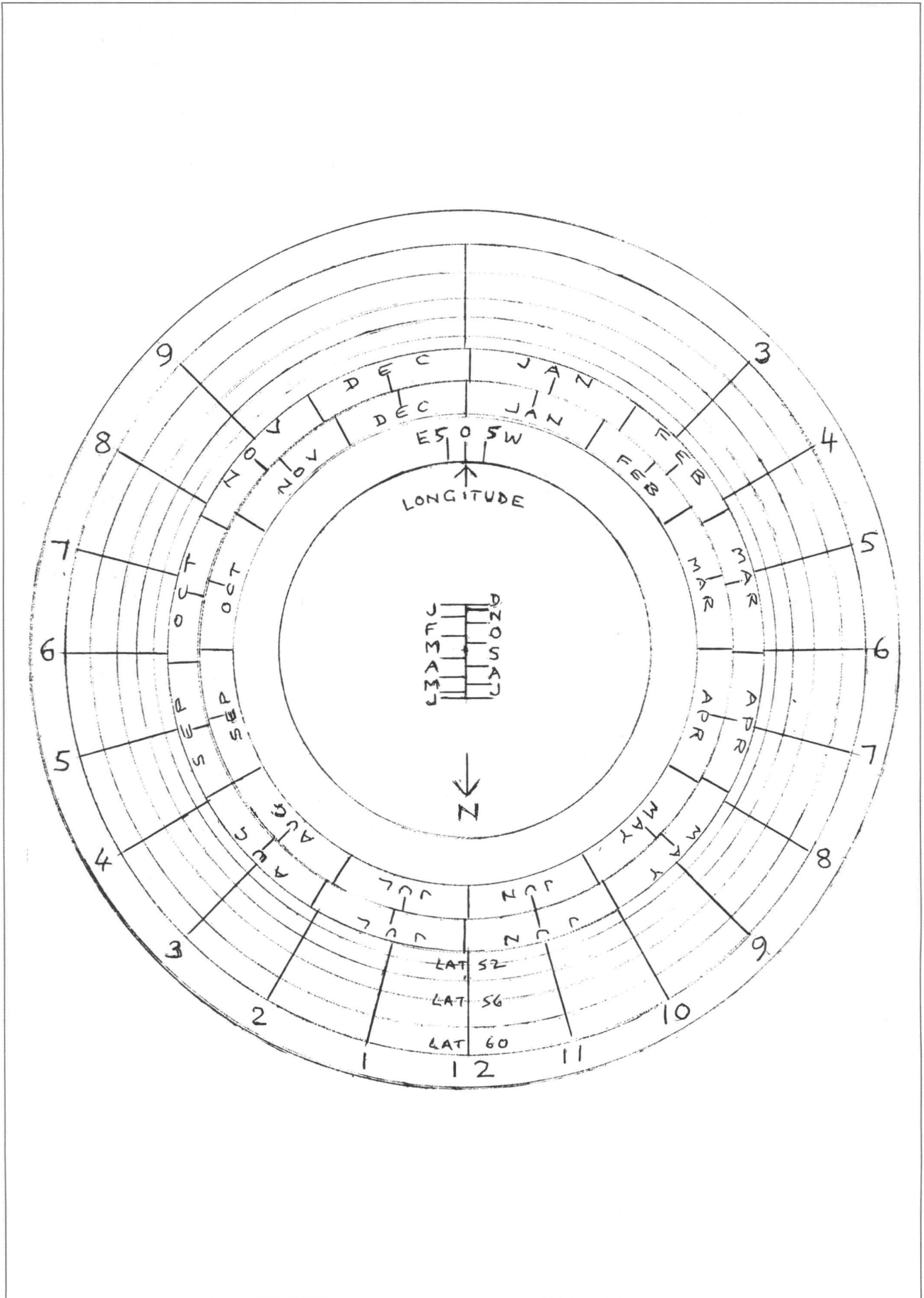

Fig.1 Circular analemmatic dial, set for longitude zero and 1st September

HONORARY OFFICIALS OF THE BRITISH SUNDIAL SOCIETY

Patron: The Rt. Hon. The Earl of Perth P.C.

President: Sir Francis Graham-Smith F.R.S.

Vice-President: M. René R.-J. Rohr (France)

Chairman: Mr. Christopher St.J.H. Daniel

General Secretary: Mr. D. A. Bateman

Finance: Mr. G. P. Stancey

Membership: Mr. Robert B. Sylvester

Bulletin Editor: Dr. M.W. Stanier

COUNCIL MEMBERS

Mr. Graham Aldred 4 Sheardhall Avenue Disley, STOCKPORT Cheshire SK12 2DE	(Restoration) Tel: 01663 762415 graham_aldred@ iclway.co.uk	Dr. M.W. Stanier 70 High Street Swaffham Prior CAMBRIDGE CB5 0LD	(Editor) Tel: 01638 741328 margaretws@stanier- cambs.demon.co.uk
Mr. D.A. Bateman 4 New Wokingham Road CROWTHORNE Berks RG45 7NR	(Secretary) Tel: 01344 772303 douglas.bateman @btinternet.com	Mr. Robert B. Sylvester Windycroft, Alexander Place ASKAM-IN-FURNESS Cumbria LA16 7BT	(Membership) Tel: 01229 465536
Mr. John Churchill 55 Rushington Avenue MAIDENHEAD Berkshire SL6 1BY	(Advertising) Tel: 01628 627382 john_churchill@ talk21.com	Mrs. Jane Walker 1 Old School Lane West Lydford SOMERTON Somerset TA11 7JP	(Education) Tel: 01963 240421
Mr. C.St.J.H. Daniel 8 The Maltings, Abbey Street FAVERSHAM Kent, ME13 7DU	(Chairman) Tel: 01795 531804 csth,daniel@ talk21.com	Miss R.J. Wilson Hart Croft 14 Pear Tree Close CHIPPING CAMPDEN Gloucestershire GL55 6DB	(Biographical Projects) Tel: 01386 841007
Mr. P. Nicholson 9 Lynwood Avenue EPSOM Surrey KT17 4LQ	(Internet) Tel: 01372 725742 BSS Email List sundiweb@aol.com Piers N@aol.com	Mr. A. O. Wood 5 Leacey Court CHURCHDOWN Gloucestershire GL3 1LA	(Mass Dials) Tel: 01452 712953 bssaow@joymail.com
Mr. P. Powers 16 Moreton Avenue HARPENDEN Herts AL5 2ET	(Registrar) Tel: 01582 713721 patrick_powers@ compuserve.com	Dr. I.D.P. Wootton Cariad Cottage Cleeve Road GORING-ON-THAMES Oxon RG8 9BD	(Vice Chairman) Tel: 01491 873050 i.wootton@btinternet. com
Mrs. Anne Somerville Mendota Middlewood Road HIGHER POYNTON Cheshire SK12 1TX	(Archival Records) Tel: 01625 872943	Mr. D.A. Young Brook Cottage 112 Whitehall Road CHINGFORD London E4 6DW	Tel: 0181 5294880 davidsun@lineone.net
Mr. Gerald P. Stancey 22 Peterborough Avenue OAKHAM Rutland LE15 6EB	(Treasurer) Tel: 01572 756444		

*Back numbers of the Bulletin and other BSS items may be purchased from:
Margery Lovatt, Studio 5, Parndon Mill, Harlow, Essex, CM20 2HP. Tel: 01279 452974*

